

A DRT Tutorial

Hans Kamp

University of Stuttgart
University of Texas, Austin

The beginnings of Formal Semantics: Montague (Thomason (1974))

- Montague's project: Give mathematically precise definitions of the *semantic values* that expressions from some *natural language fragment* NL take in the *models* for NL .
- The semantic value of an expression α in a model M is directly computed from the syntactic structure of α (according to the chosen syntax for NL).
- The computation is *strictly compositional*:

The semantic value of a syntactically complex expression is always a function of the semantic values of its immediate syntactic constituents.

Montague Grammar

- Montague: Natural languages are just like the artificial languages of formal logic (such as the *Predicate Calculus* or the *Typed Lambda Calculus*).

- Montague Grammar has been immensely influential.

A very large amount of work has been done in it on the semantics of many natural languages and continues to be done today.

Discourse Representation Theory

- Discourse Representation Theory (DRT, Kamp (1981*b*), Kamp (1981*a*), Kamp and Reyle (1993), Kamp et al. (2011), Beaver et al. (2015)) was developed as an alternative to Montague Grammar.

DRT differs from Montague Grammar in two fundamental respects:

- DRT is a theory of multi-sentence discourse (and not just of single sentences)
- DRT is a *logical form* theory:

Expressions α from the given natural language NL are assigned logical forms/semantic representations K_α from a *logical form formalism*.

The semantic values of α are determined via its logical form K_α .

Discourse Representation Theory

- The logical forms/semantic representations of DRT are known as *Discourse Representation Structures* (DRSs).
- DRT's logical form formalisms are known as *DRS-languages*.
- DRS-languages are defined by (a) a syntax, together with (b) a model-theoretic semantics
(as in standard presentations of the Predicate Calculus or Typed Lambda-Calculus).
- DRS-languages vary both in their vocabulary and in the syntactic constructs they admit.
- In this tutorial neither the syntax nor the semantics of any DRS-languages will be explicitly defined.

Most details should be clear from the examples we will discuss.
If not, ask!

Discourse Representation Theory

- Reasons for why DRT deviates in these ways from MG:
- Natural language sentences tend to contain many elements that control the ways in which they fit together with the antecedent discourse.

Prominent among these are tenses and pronouns.

Trans-sentential Anaphora

- Some examples of how pronouns and tenses contribute to discourse cohesion.

- (1) a. Pedro owns a donkey. He beats it.
- b. John found a cell phone on his desk. Someone had left it there by mistake.
- c. A man and a woman entered the pub. She was quite elegantly dressed, but he was in jeans, heavy boots and a lumberjack shirt.
- d. I had an idea. It is about how to make a good pet out of a raccoon. You give it a jar with a lid that is very hard but not impossible to get off. ...

Discourse Representation Theory

- (2) a. When Alan opened his eyes, the first thing he saw was his wife. She **smiled**.
- b. When Alan opened his eyes, the first thing he saw was his wife. She **was smiling**.
- c. John **proved** a well-known conjecture in twenty pages.
Mary **proved** it in ten pages.
- d. John **proved** a well-known conjecture in twenty pages.
Mary **had proved** it in ten pages.
- e. John **was proving** a well-known conjecture in twenty pages.
Mary **was proving** it in ten pages.

Discourse Representation Theory

- DRT's strategy for dealing with inter-sentential relations in discourse:
- Construct the logical form for a discourse incrementally, sentence by sentence.
- Design your logical form language L_{DRS} in such a way that:
the logical form $K_{\langle S_1, \dots, S_n \rangle}$ for the discourse segment that has been interpreted so far can serve as is as *discourse context* in the logical form construction for S_{n+1} .

That is, design L_{DRS} in such a way that:

'Content \equiv Context'

'Donkey Discourses'

(134.a) Pedro owns a donkey. He beats it.

(3) DRS:

x y
$Pedro(x)$ $donkey(y)$
$owns(x, y)$

(4) Translation into Predicate Logic:

$$(\exists x)(\exists y)(x = Pedro \ \& \ donkey(y) \ \& \ own(x, y))$$

(5) (Truth definition for Simple DRSs)

A DRS $K = \langle U_K, CS_K \rangle$ is true in a model M iff there is a function f from U_K into U_M such that for each condition $P(x_1, \dots, x_n)$ in CS_K $\langle f(x_1), \dots, f(x_n) \rangle \in I_M(P)$.

'Donkey Discourses'

(6) DRS for 1st sentence of (134.a)

$u \quad v$
$u = x \quad v = y$ $beats(u, v)$

(7) DRS for 1st + 2nd sentence of (134.a)

$x \quad y \quad u \quad v$
$Pedro(x) \quad donkey(y)$ $owns(x, y)$ $u = x \quad v = y$ $beats(u, v)$

'Donkey Sentences'

(8) A 'donkey sentence' (Geach (1962))

If Pedro owns a donkey, he beats it.

(9)

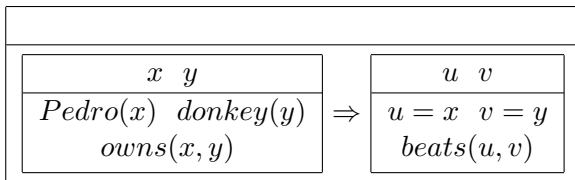

DRS Construction

- DRS construction for the two sentence discourse (134.a):

(134.a) Pedro owns a donkey. He beats it.

(10)

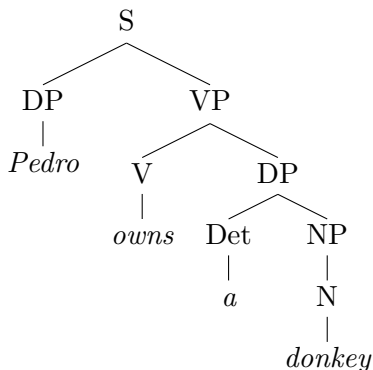

DRS Construction

(11)

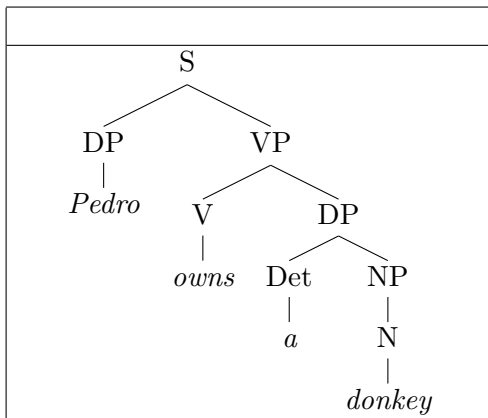

DRS Construction

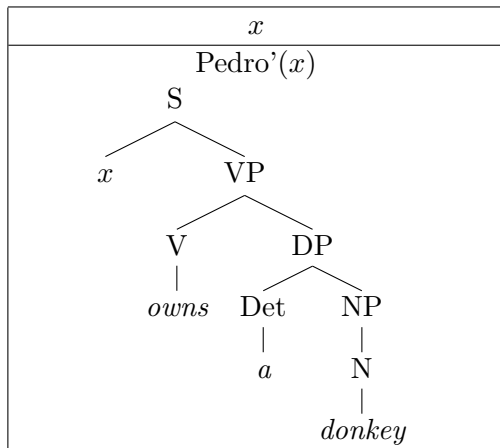

DRS Construction

(13)

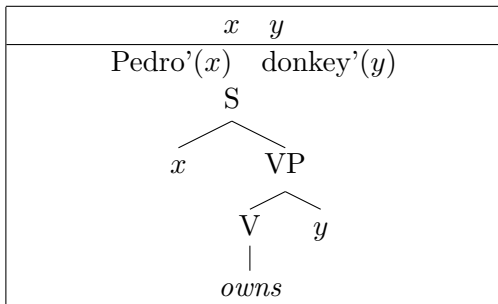

(14)

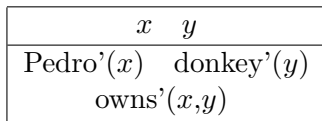

DRS Construction

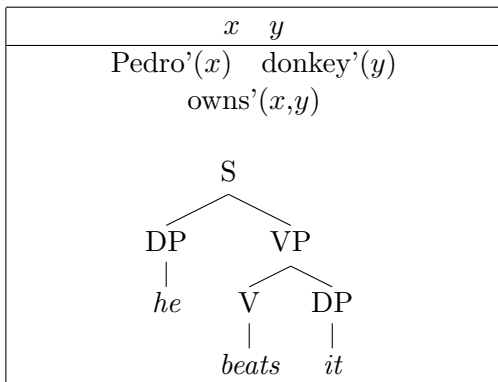

DRS Construction

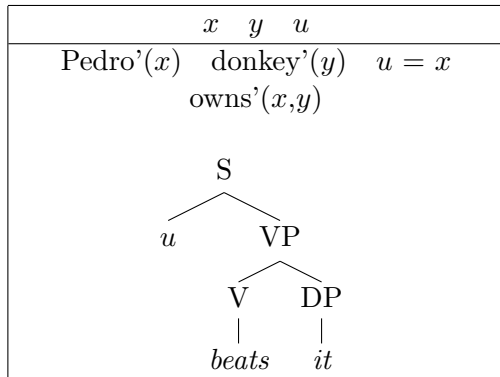

DRS Construction

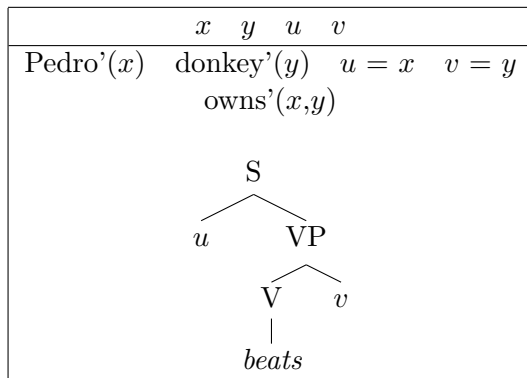

b.

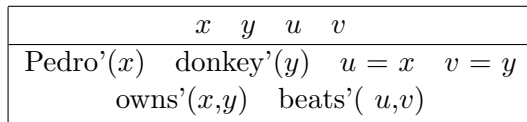

DRS Construction: 'If Pedro owns a donkey he beats it'

(18)

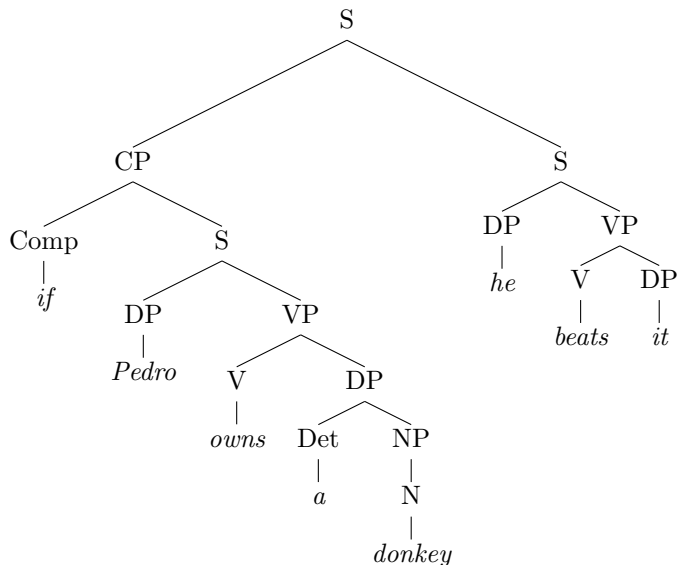

DRS Construction

(19)

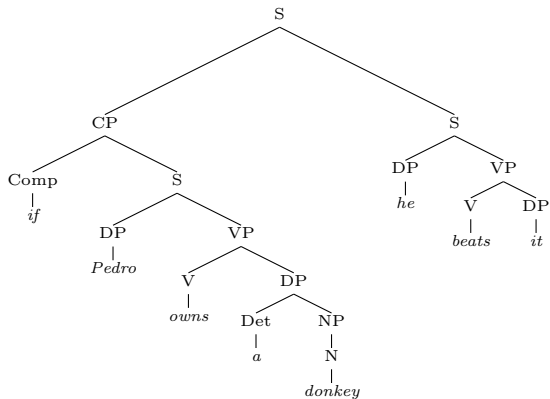

DRS Construction

(20)

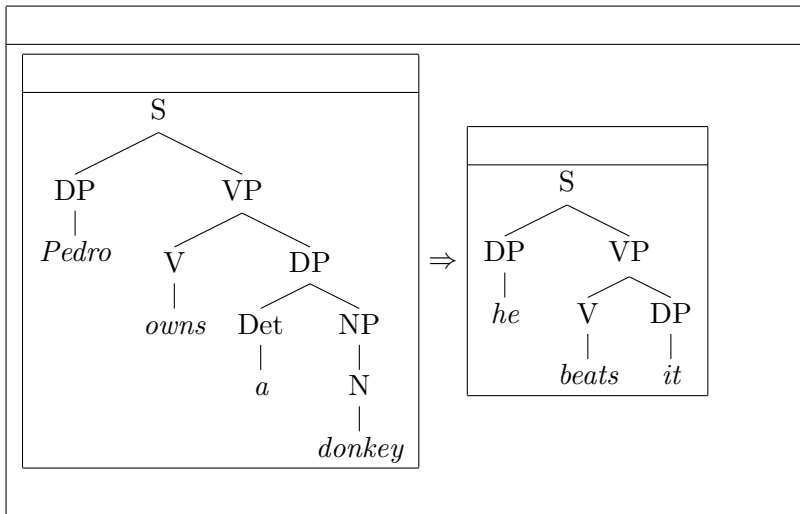

DRS Construction

(21)

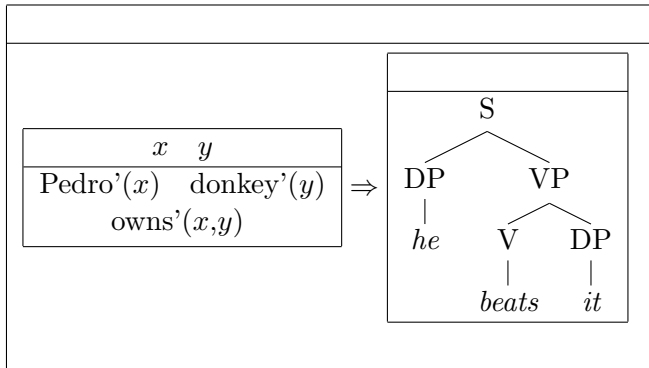

DRS Construction

Two principles governing the DRT treatment of conditionals:

- (22) The semantic representation for the antecedent of a conditional can play the part of a discourse context in the interpretation of the conditional's consequent.

A consequence of this principle for the interpretation of pronouns:

- (23) The discourse referents occurring in the Universe of the DRS representing the antecedent of a conditional may be used as anaphoric antecedents for pronouns occurring in its consequent.

DRS Construction

(24)

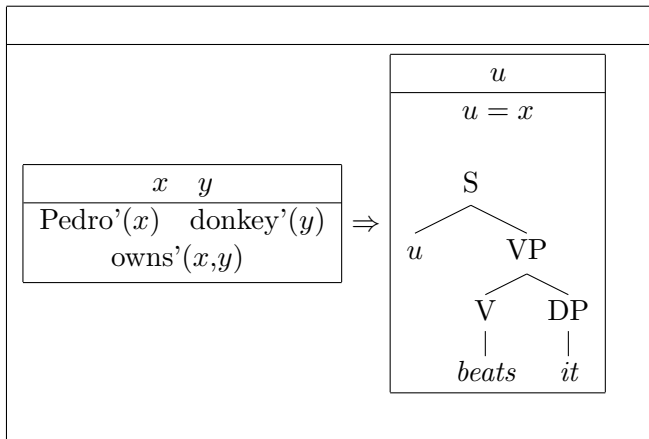

DRS Construction

(25)

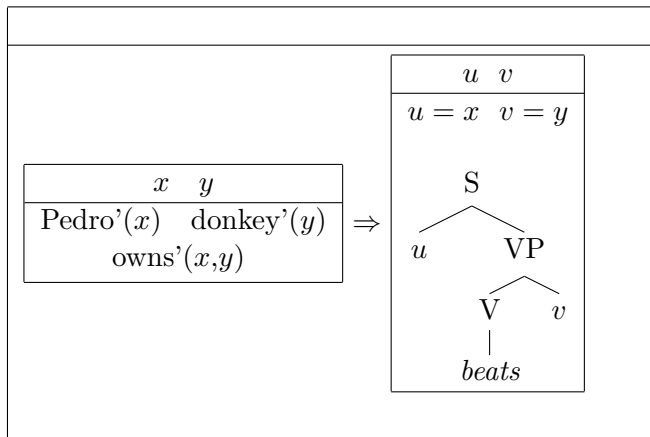

DRS Construction

(26)

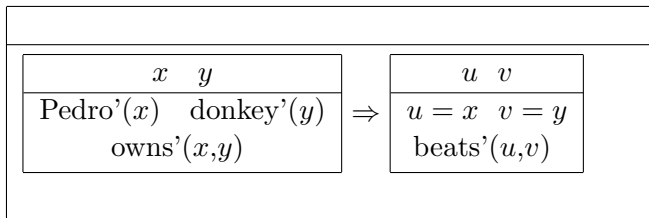

Verification conditions for conditional DRS Conditions

(27) An embedding function f into the model M verifies $K_1 \Rightarrow K_2$ in M iff

every function g which

(i) extends f with values in U_M for the drefs in the Universe of K_1 and

(ii) verifies in M the DRS Conditions in the Condition Set of K_1 can be extended to a function h that in addition assigns values in U_M to the drefs in the Universe of K_2 and verifies in M the DRS Conditions in the Condition Set of K_2 .

Verification conditions for conditional DRS Conditions

Verification condition for the conditional DRS Condition in (26):

- (28) The DRS condition of (26) is verified in M iff every way of assigning an entity \mathbf{d}_x from the Universe U_M of M to x and an entity \mathbf{d}_y from U_M to y such that \mathbf{d}_x is the bearer of the name *Pedro* in M , \mathbf{d}_y is a donkey in M and \mathbf{d}_x owns \mathbf{d}_y in M is such that \mathbf{d}_x beats \mathbf{d}_y in M .

This then also gives the truth conditions for the entire DRS (26):

- (26) is verified in M iff the empty function \emptyset verifies the conditions in the Condition Set of (26) in M ; and this is the case if and only if (28) holds.

Verification conditions for conditional DRS Conditions

Question: What are we to say about (142) when Pedro owns two donkeys of which he beats one but not the other?

(142) If Pedro owns a donkey he beats it.

Other types of donkey sentences:

- (29) a. If Pedro finds a donkey that he likes he buys it.
b. If Pedro likes a donkey he takes good care of it.

A challenge for the present account (Cooper (1979))

- (30) Everyone who had a quarter in his pocket put it in the meter (for the parking pace in which she had parked her car).

DRS Construction

Donkey sentences with *every* and donkey sentences with *if*:

- (31) a. If a farmer owns a donkey, he beats it.
b. Every farmer who owns a donkey beats it.

(32) a.

b.

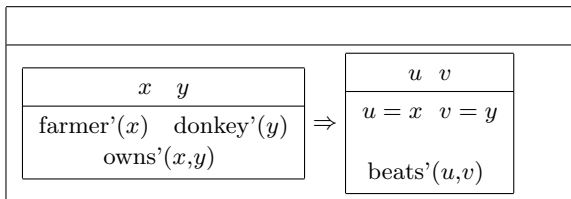

c.

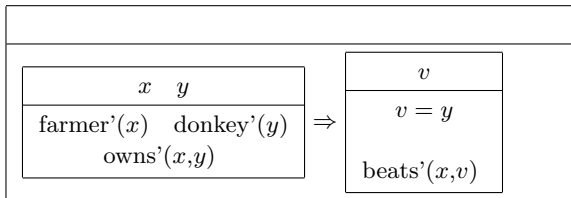

Representation of Quantifications

(33) Every farmer who owns a donkey beats it.

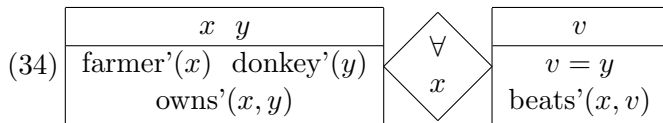

Complex DRS Conditions

Verification condition for Universal Duplex Condition:

- (35) f verifies the DRS condition in (34) in M if every extension g such that $f \subseteq_{\{x,y\}} g$ which verifies the conditions in the left hand DRS can be extended to a function h such that $g \subseteq_{\{v\}} h$ which verifies the conditions in the right hand side DRS.

Complex DRS Conditions

(36) a. Most farmers who own a donkey beat it.

b.

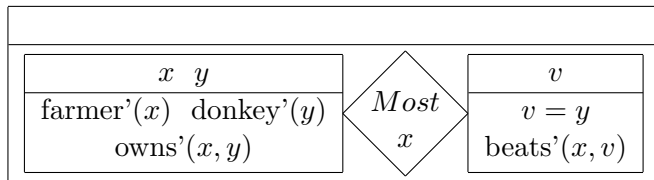

Complex DRS Conditions

(37) f verifies the DRS condition in (36.b) in M if the following sets X and Y stand to each other in the relation $|Y| > 1/2 \cdot |X|^1$, where X and Y are defined as follows:

X = the set of individuals \mathbf{d} from U_M such that there are one or more extensions g of f such that $f \subseteq_{\{x,y\}} g$, g verifies the conditions in the left hand DRS and $g(x) = \mathbf{d}$.

Y = the set of individuals \mathbf{d} from U_M such that there are one or more extensions g of f such that $f \subseteq_{\{x,y\}} g$, g verifies the conditions in the left hand DRS, $g(x) = \mathbf{d}$ and g can be extended to a function h such that $g \subseteq_{\{v\}} h$ which verifies the conditions in the right hand side DRS.

¹by $|Y|$ we mean the *cardinality* of the set Y , that is the number of its elements. (What this comes to in cases where, where Y is infinite can be found in any proper introduction to Set Theory, but the matter is not crucial for what I am trying to get across here)

More Complex DRS Conditions

(38) Pedro doesn't own a donkey. He beats it.

(39)

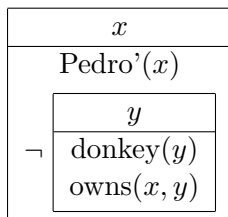

- Verification conditions for negation Conditions:

f verifies ' $\neg K$ ' in M iff there is no embedding function g such that $f \subseteq_{U_K} g$ and g verifies in M all the conditions in the Condition Set of K .

Complex DRS Conditions

Minimal specifications for a complex DRS Condition:

1. Its verification conditions;
2. The accessibility relations involved. There are several questions that need to be settled in this connection for each type of complex DRS Condition:
 - (i) for each of the constituent DRSs K of the complex Condition, from which Condition Sets of other DRSs that cooccur with K in some larger DRS K_0 to which the complex Condition belongs are the drefs in the Universe of K accessible?
 - (ii) for each of the constituent DRSs K of the complex Condition, which drefs in Universes of DRSs cooccurring with K in some larger DRS K_0 to which the complex Condition belongs are accessible from (the Conditions in) K 's Condition Set?

Complex DRS Conditions

Accessibility, an example.

(40)

a. If it is not the case that this pot breaks if you hit it with a hammer, then it is not the case that it will break if you hit it with a screwdriver.

b.

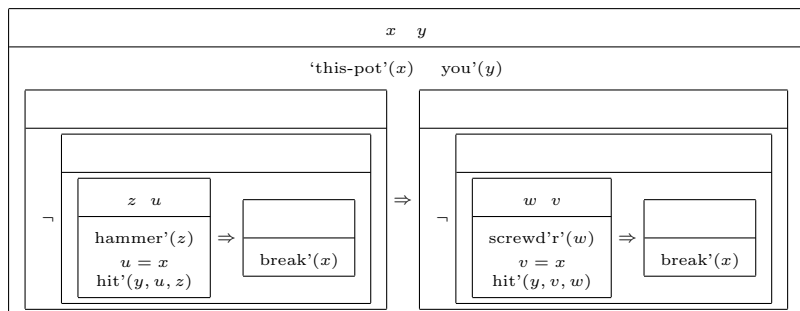

Complex DRS Conditions

(41) a. Pedro owns a donkey or he owns a mule.

b.

x					
$\text{Pedro}'(x)$					
<table border="1" style="border-collapse: collapse; width: 100%; text-align: center;"> <tr> <td style="padding: 5px;">y</td> </tr> <tr> <td style="padding: 5px;">$\text{donkey}'(y)$ $\text{owns}(x, y)$</td> </tr> </table>	y	$\text{donkey}'(y)$ $\text{owns}(x, y)$	\vee <table border="1" style="border-collapse: collapse; width: 100%; text-align: center;"> <tr> <td style="padding: 5px;">$u \quad z$</td> </tr> <tr> <td style="padding: 5px;">$u = x \quad \text{mule}'(z)$ $\text{owns}(u, z)$</td> </tr> </table>	$u \quad z$	$u = x \quad \text{mule}'(z)$ $\text{owns}(u, z)$
y					
$\text{donkey}'(y)$ $\text{owns}(x, y)$					
$u \quad z$					
$u = x \quad \text{mule}'(z)$ $\text{owns}(u, z)$					

• Verification conditions for disjunctive DRS Conditions:

an embedding function f verifies $K_1 \vee K_2$ in a model M iff

(i) there is an embedding function g such that $f \subseteq_{U_{K_1}} g$ and g verifies the Conditions in the Condition Set of K_1 or

(ii) there is an embedding function h such that $f \subseteq_{U_{K_2}} h$ and h verifies the conditions in the Condition Set of K_2 (not excluding the possibility that there both is such a function g and such a function h).

Complex DRS Conditions

(42) Either there is no bathroom in this house or it is in a funny place.

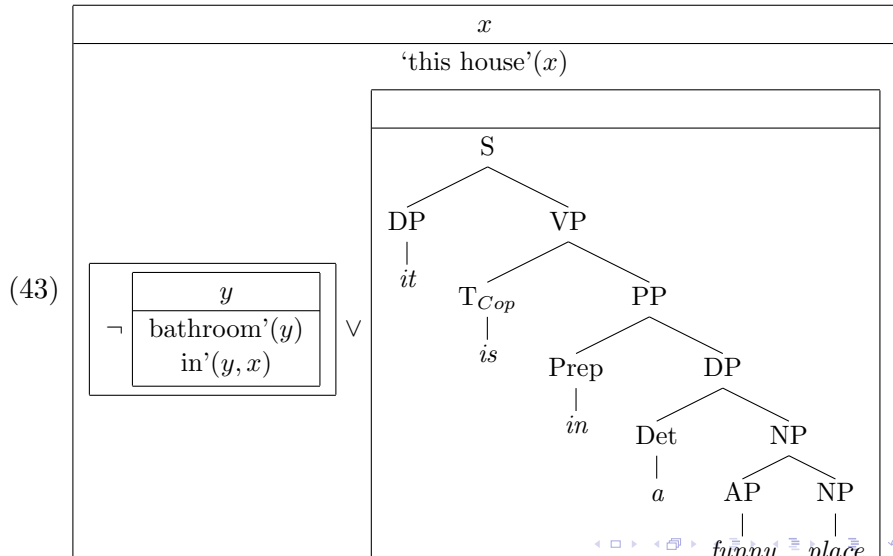

Complex DRS Conditions

(44)

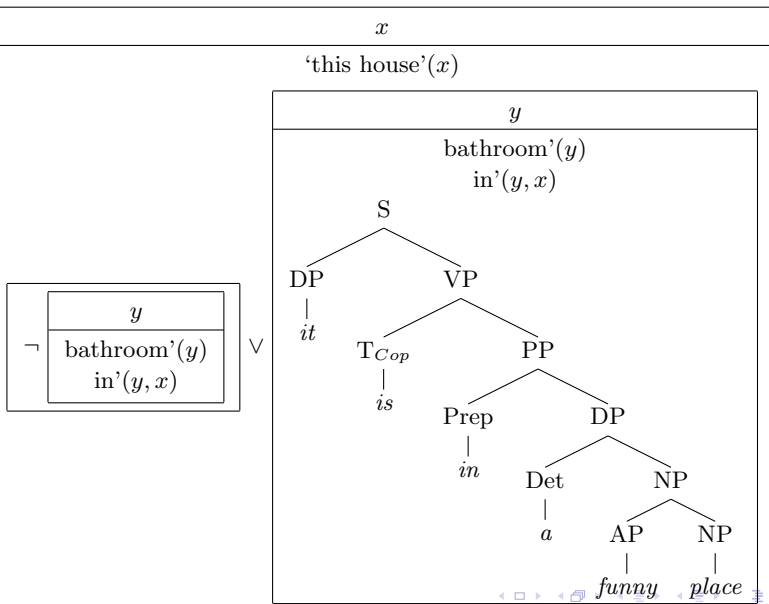

Complex DRS Conditions

(45)

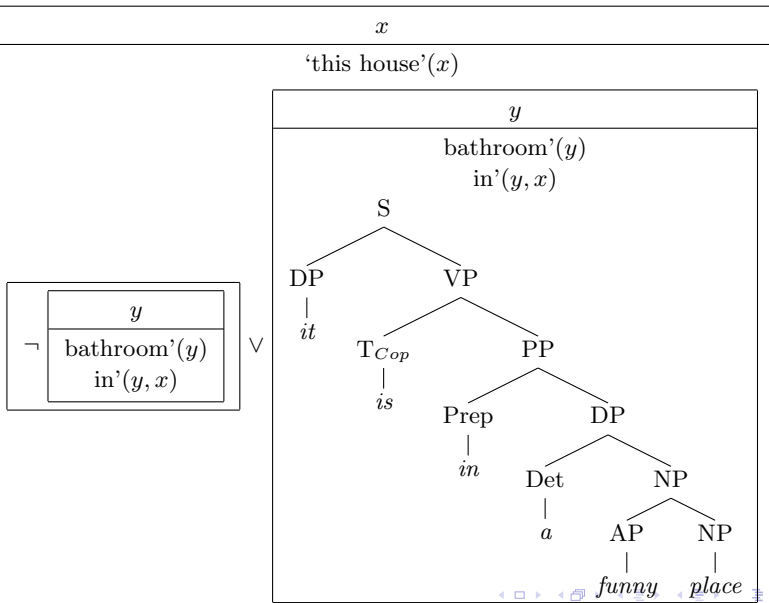

Complex DRS Conditions

(46)

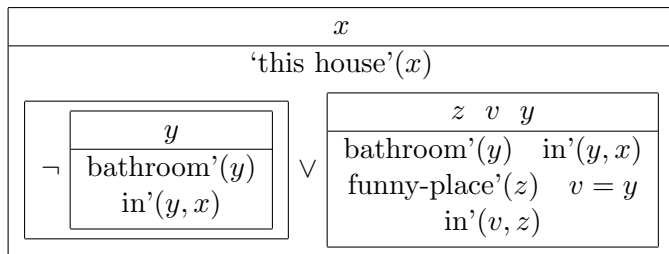

Partee's 'ball example'

- (47) a. One of the ten balls is not in the bag. It is under the sofa.
b. Nine of the ten balls are in the bag. It is under the sofa.
c. All but one of the ten balls are in the bag. It is under the sofa.

Partee's 'ball example'

(48) a.

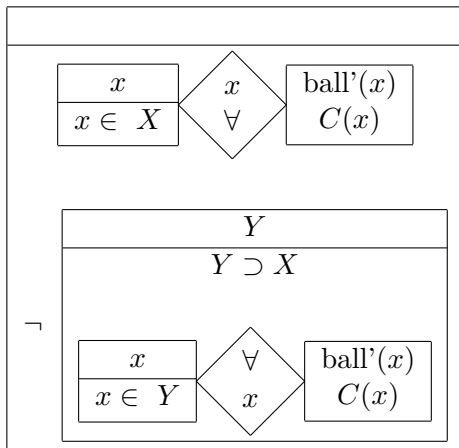

b. $|X| = 10$

Partee's 'ball example'

(49)

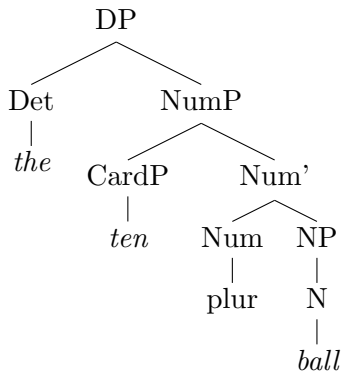

Partee's 'ball example'

(50)

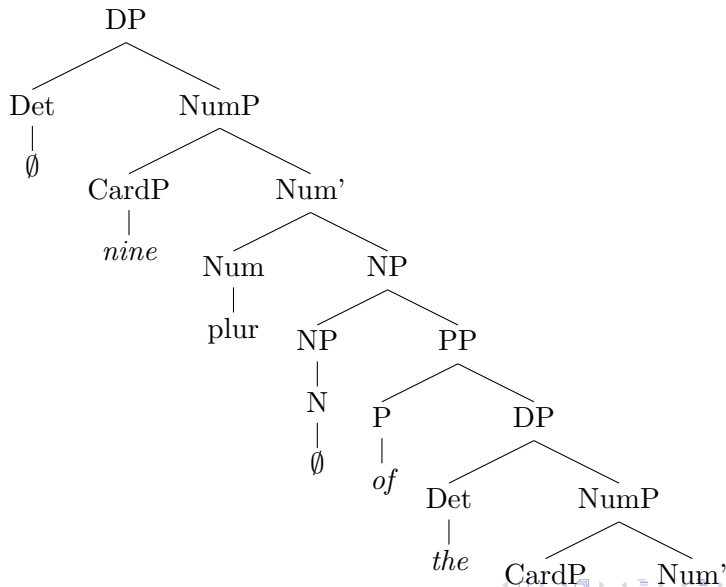

Partee's 'ball example'

(51)

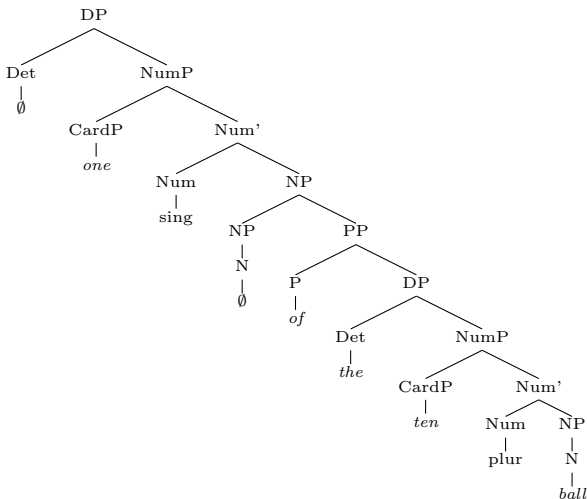

Partee's 'ball example'

(52) a.

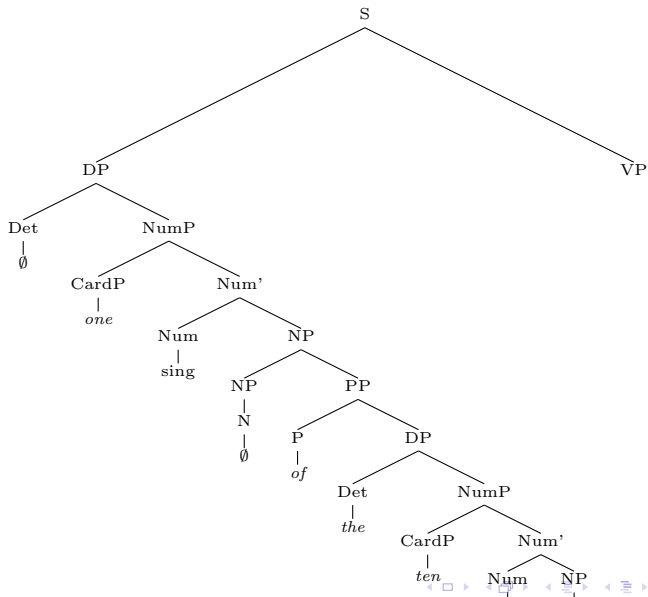

Partee's 'ball example'

(52.b)

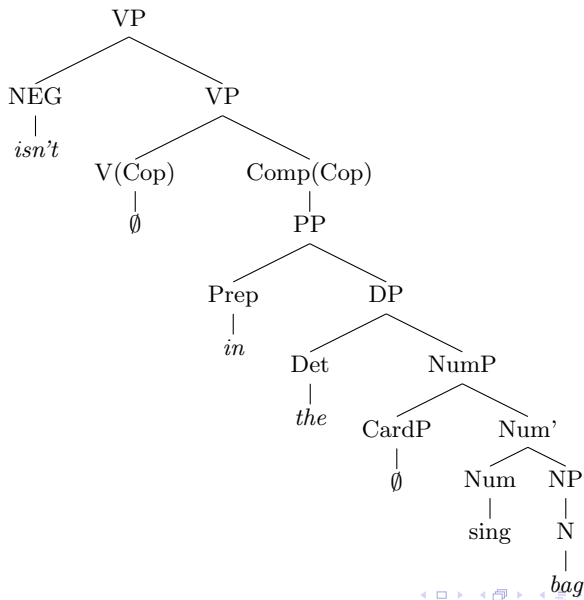

Partee's 'ball example'

(53)

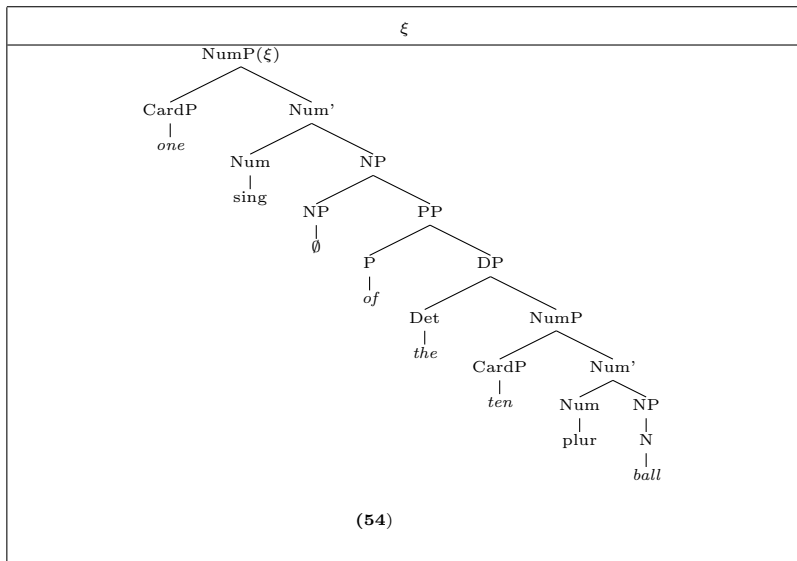

Partee's 'ball example'

(54)

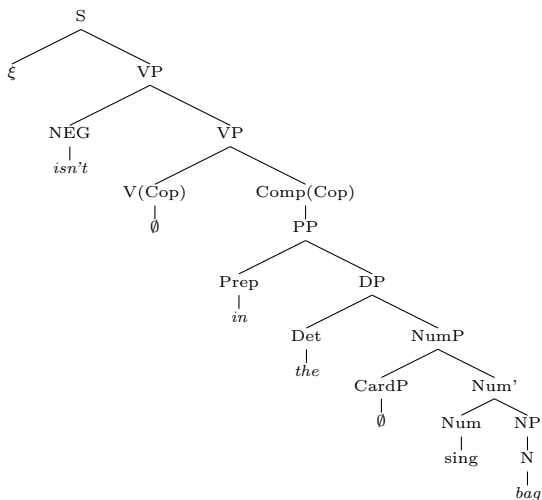

Partee's 'ball example'

(55)

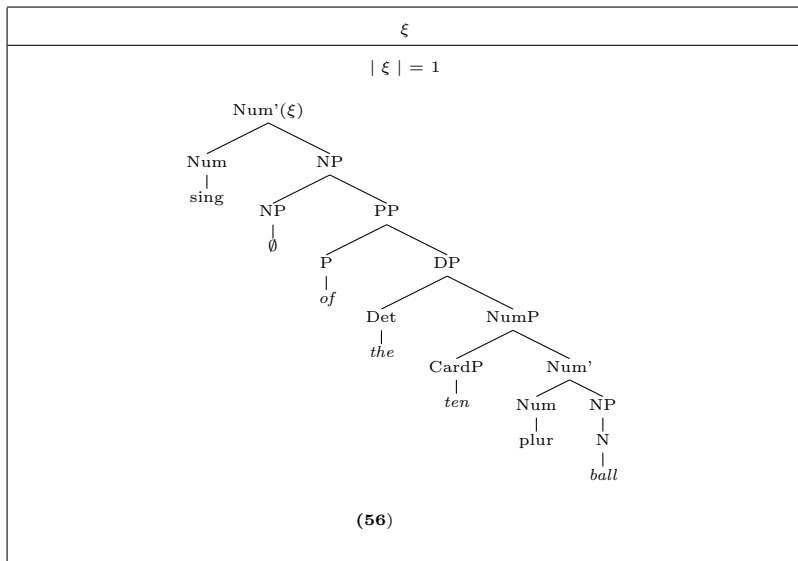

Partee's 'ball example'

(56)

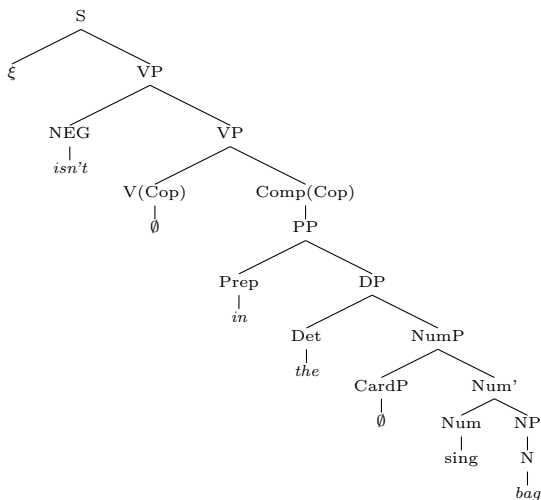

Partee's 'ball example'

(57)

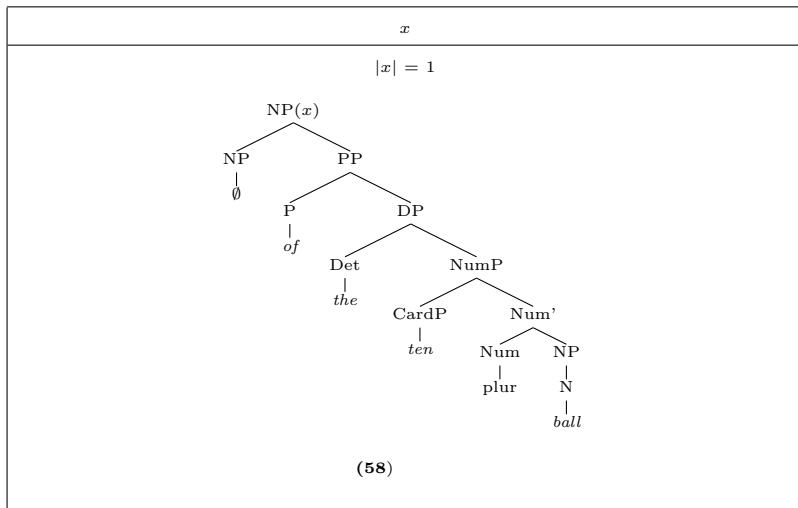

Partee's 'ball example'

(58)

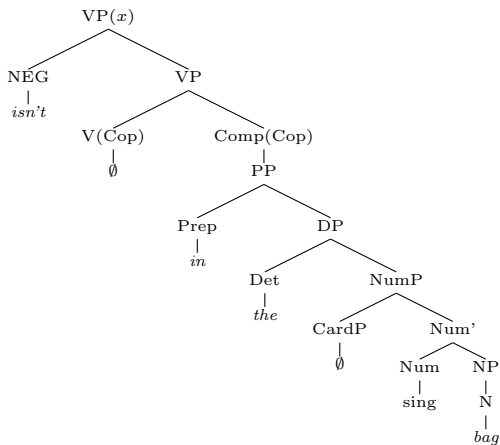

Partee's 'ball example'

(59)

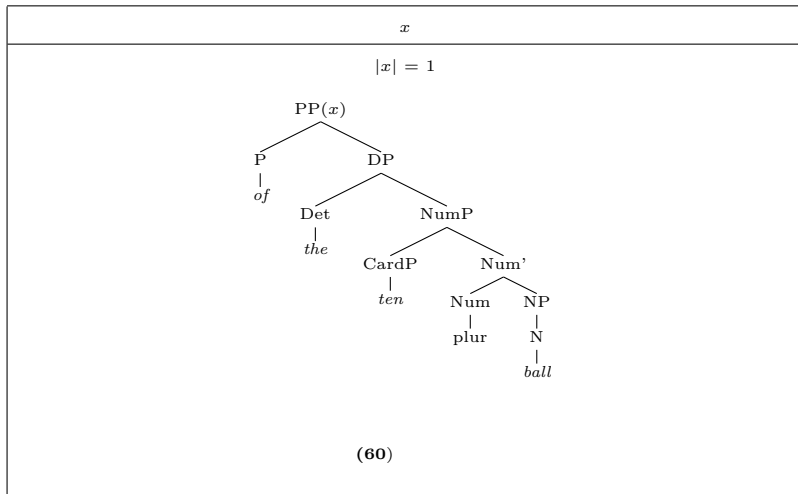

Partee's 'ball example'

(60)

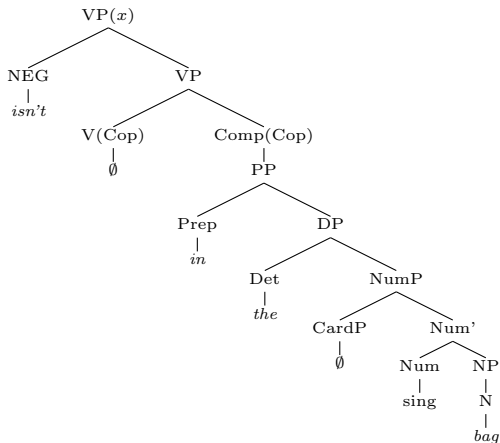

Partee's 'ball example'

(61)

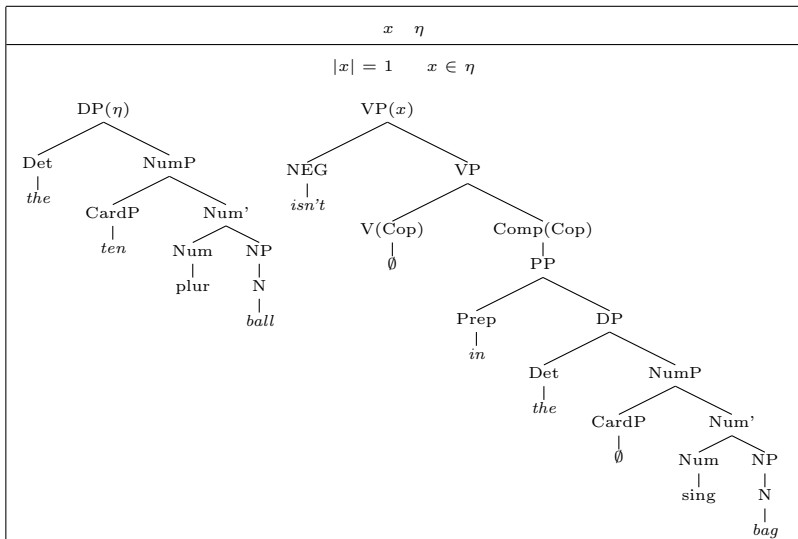

Partee's 'ball example'

(62)

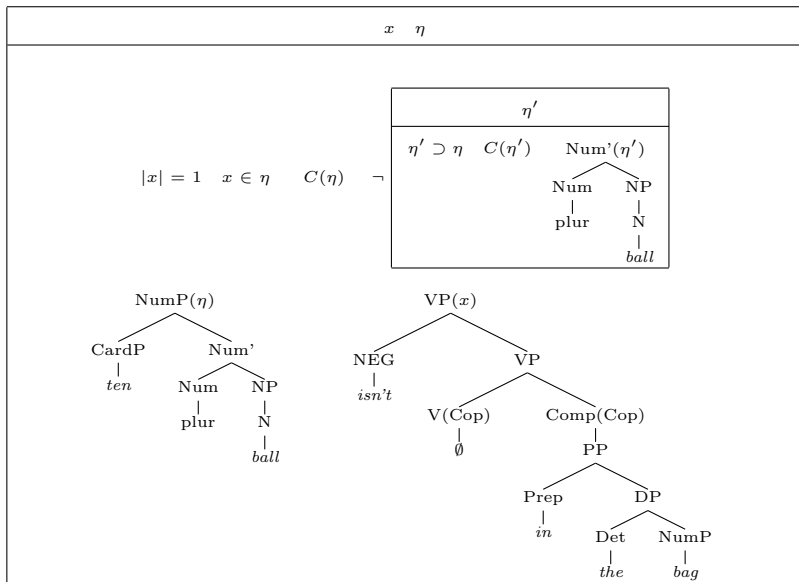

Partee's 'ball example'

(63)

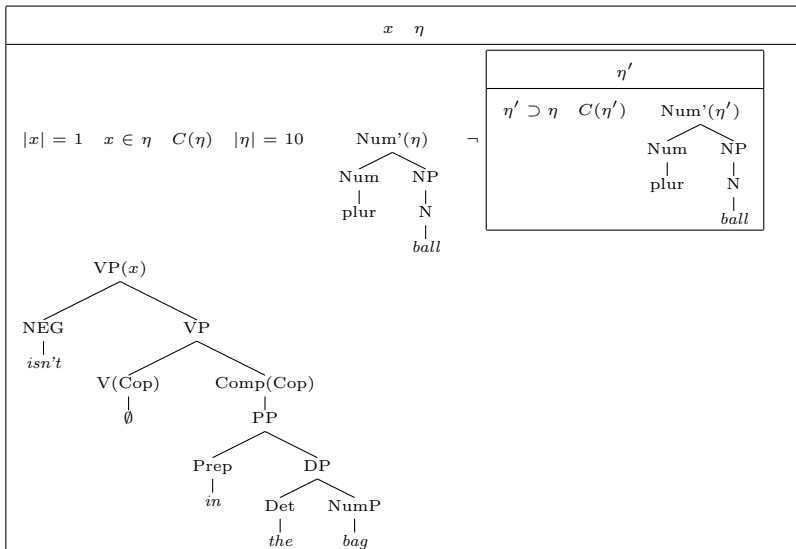

Partee's 'ball example'

(64)

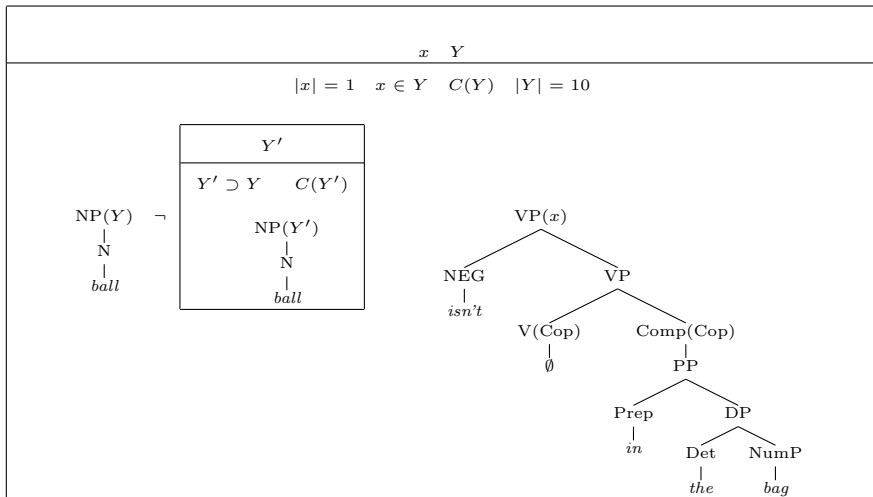

Partee's 'ball example'

(65)

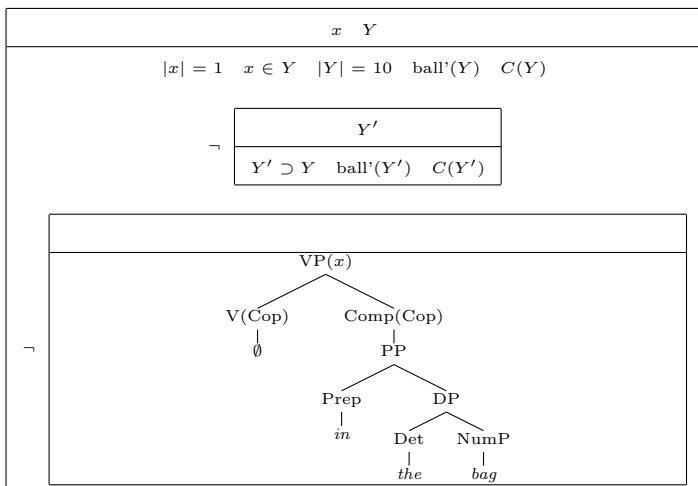

Partee's 'ball example'

(66)

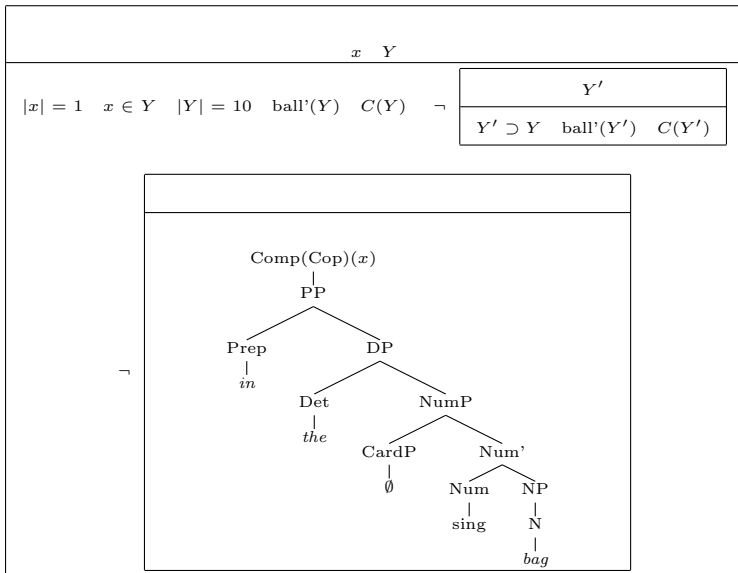

Partee's 'ball example'

(67)

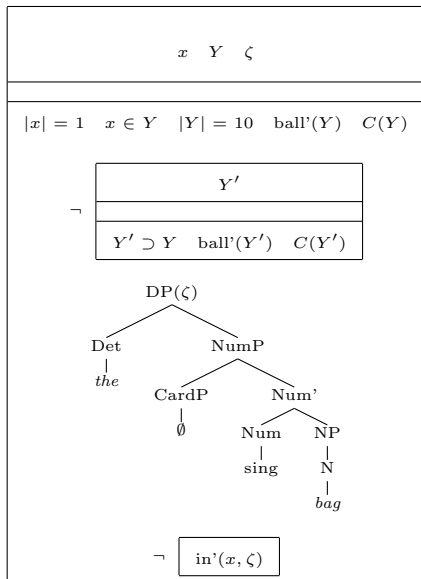

Partee's 'ball example'

(68)

x	Y	z			
$ x = 1$	$x \in Y$	$ Y = 10$			
\neg		$\text{ball}'(Y) \quad C(Y)$			
<table border="1" style="margin: auto; border-collapse: collapse;"> <tr> <td style="text-align: center; padding: 5px;">Y'</td> </tr> <tr> <td style="padding: 5px;">\neg</td> </tr> <tr> <td style="padding: 5px;">$Y' \supset Y \quad \text{ball}'(Y') \quad C(Y')$</td> </tr> </table>			Y'	\neg	$Y' \supset Y \quad \text{ball}'(Y') \quad C(Y')$
Y'					
\neg					
$Y' \supset Y \quad \text{ball}'(Y') \quad C(Y')$					
<table border="1" style="margin: auto; border-collapse: collapse;"> <tr> <td style="padding: 5px;">\neg</td> <td style="padding: 5px;">$\text{in}'(x, z)$</td> </tr> </table>			\neg	$\text{in}'(x, z)$	
\neg	$\text{in}'(x, z)$				
$\text{bag}'(z)$	$C'(z)$	\neg			
<table border="1" style="margin: auto; border-collapse: collapse;"> <tr> <td style="text-align: center; padding: 5px;">Z'</td> </tr> <tr> <td style="padding: 5px;">$Z' \supset z \quad \text{bag}'(Z') \quad C'(Z')$</td> </tr> </table>			Z'	$Z' \supset z \quad \text{bag}'(Z') \quad C'(Z')$	
Z'					
$Z' \supset z \quad \text{bag}'(Z') \quad C'(Z')$					

Partee's 'ball example'

If the uniqueness conditions and the domain restriction predications of (68) are ignored:

x	Y	z
$ x = 1$	$x \in Y$	$ Y = 10$
$\text{ball}'(Y)$		
$\neg \text{in}'(x, z)$		
$\text{bag}'(z)$		
$C'(z)$		

Partee's 'ball example'

(69)

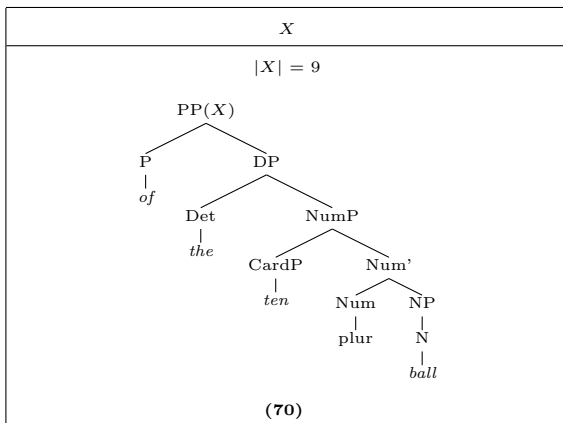

Partee's 'ball example'

(70)

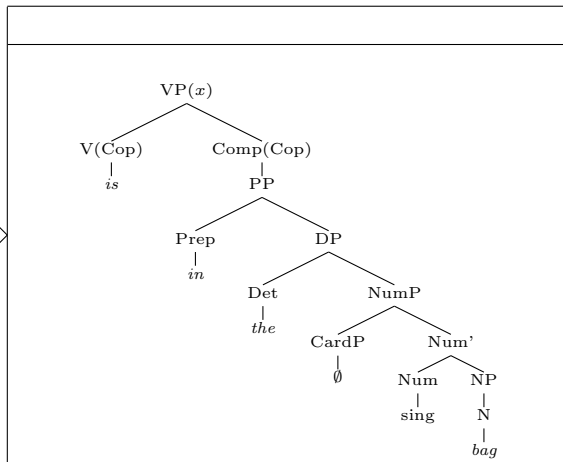
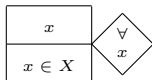

The trans-sentential Powers of Tense: some examples

(71)

- a. John proved the theorem in twenty lines. Mary proved it in ten lines.
- b. John proved the theorem in twenty lines. Mary had proved it in ten lines.
- c. John was proving the theorem in twenty lines. Mary was proving it in ten lines.

(72)

When Alan opened his eyes he saw his wife who was standing by his bedside.

- (i) She smiled.
- (ii) She was smiling.

The trans-sentential Powers of Tense: some examples

(73) (Webber (1988))

- a. Fred went to Rosie for dinner. He came home in a state of euphoria.
- b. Fred went to Rosie for dinner. He put on clean trousers and his nicest shirt.
- c. Fred went to Rosie for dinner. He bought flowers on the way.

(74) (Kamp & Reyle, 1993)

Bill arrived at noon. He had got up at six thirty, had cooked himself a full breakfast, and had washed up after finishing it. He had left the house in time to catch the 7.54 train at the central station.

The trans-sentential Powers of Tense: some examples

(75)

- a. Henry arrived on Wednesday. He left again on Sunday.
- b. Henry arrived on Wednesday. He would leave again on Sunday.
- c. Henry arrived on Wednesday. He will leave again on Sunday.

(76)

- a. Mary said that she felt sick.
- b. Mary said she ate an apple.
- c. Fred and Mary told us of the horrible scene they had watched when coming out of the train station. Mary said she felt sick.

The trans-sentential Powers of Tense: some examples

(77)

- a. It was predicted once that civilization would come to an end through a world-wide epidemic (in the year 3000/in the year 2000).
- b. It was predicted once that civilization will come to an end through a worldwide epidemic (in the year 3000/# in the year 2000).

(78) Mary told me last week that she was going to file for a divorce in a couple of weeks but that she would tell Fred only then that she had (filed for a divorce).

Constructing DRSs for Simple Tensed Sentences

(79) Frieda smiled.

(80)

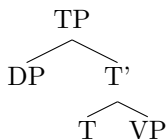

(81)

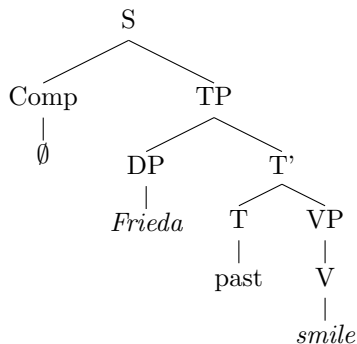

Constructing DRSs for Simple Tensed Sentences

(82) (lexical entry for the verb *smile*)

smile (V) nom
e *x*

Sel. Restr: event human

Sem.Repr: $\langle e \mid \boxed{\begin{array}{c} \\ e: smile'(\underline{x}) \end{array}} \rangle$

Constructing DRSs for Simple Tensed Sentences

(83) (lexical entry for the proper name *Frieda*)

Frieda (PN)

x

(84) Sel. Restr: human

Sem.Repr:

$\langle x \mid \boxed{\text{Frieda}'(x)} \rangle$

Constructing DRSs for Simple Tensed Sentences

(85)

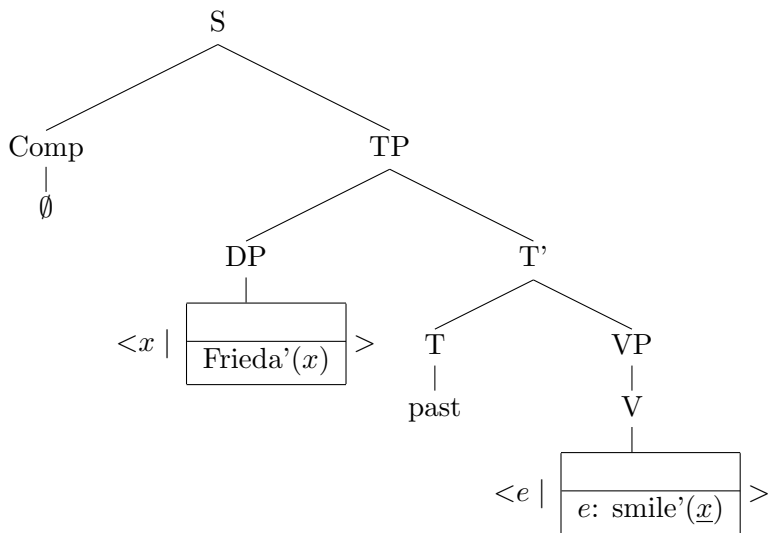

Constructing DRSs for Simple Tensed Sentences

(86)

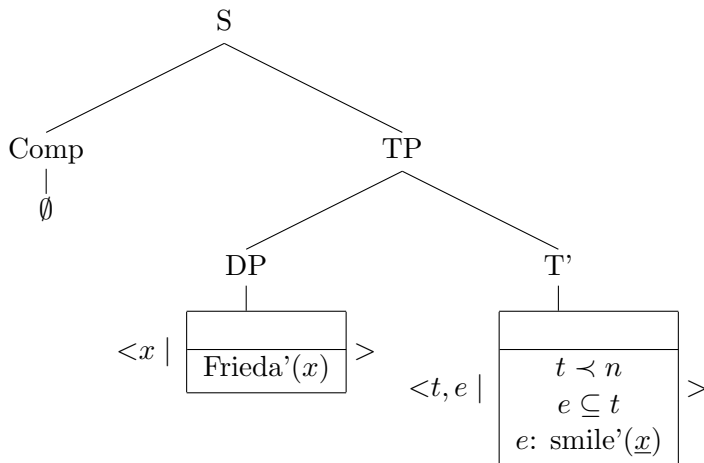

Constructing DRSs for Simple Tensed Sentences

(87)

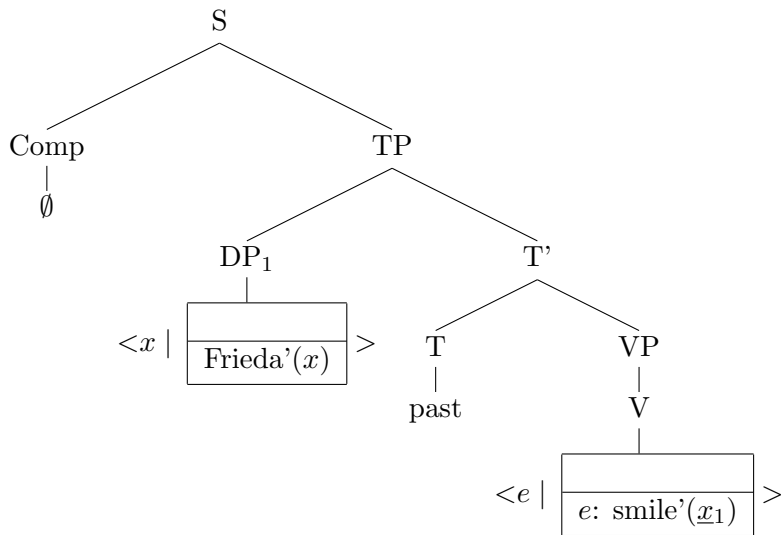

Constructing DRSs for Simple Tensed Sentences

(88)

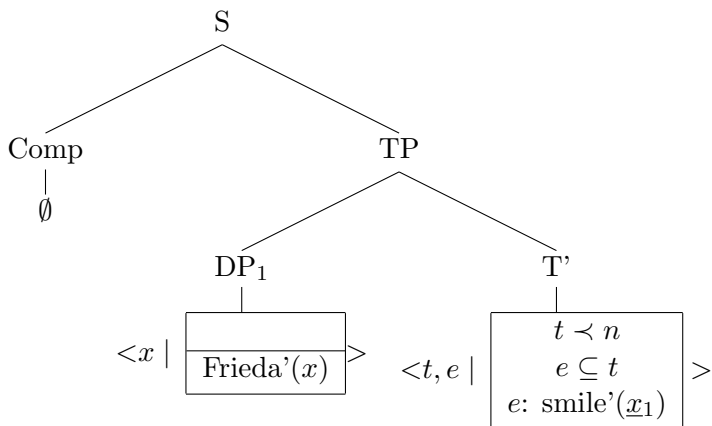

Constructing DRSs for Simple Tensed Sentences

(89)

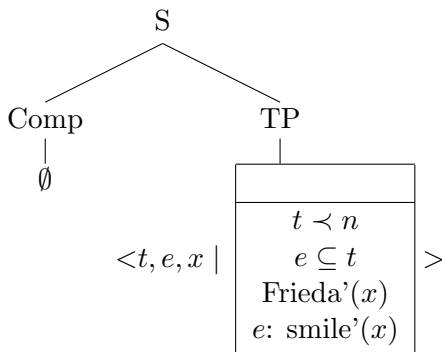

Constructing DRSs for Simple Tensed Sentences

(90)

$t \ e \ x$
$t \prec n$
$e \subseteq t$
Frieda'(x)
e: smile'(x)

Constructing DRSs for Simple Tensed Sentences

- DRS Construction for a Simple Past State-describing Sentence.

(91)

a. Frieda liked Pedro.

b.

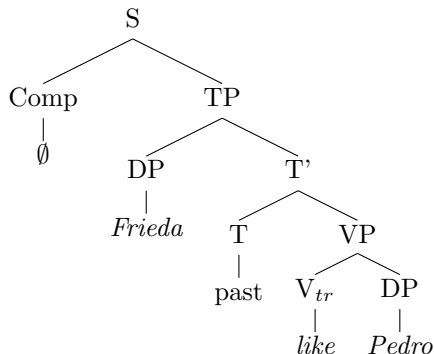

Constructing DRSs for Simple Tensed Sentences

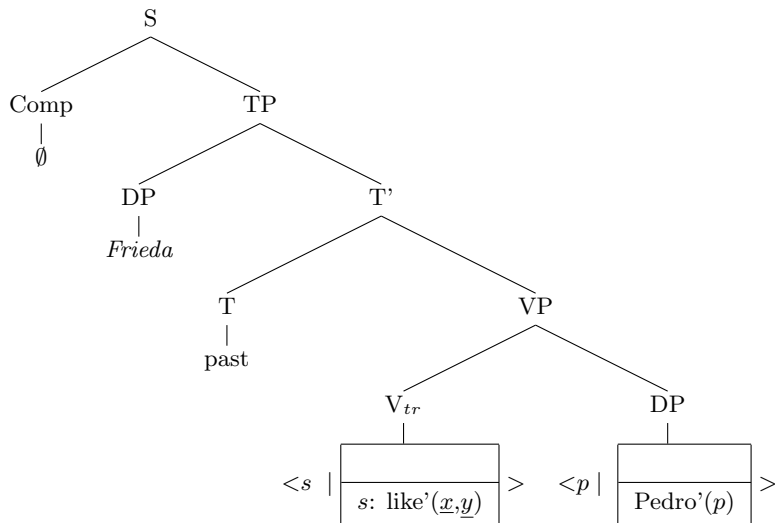

Constructing DRSs for Simple Tensed Sentences

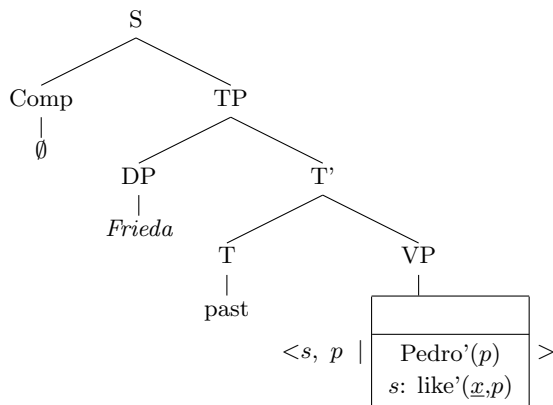

Constructing DRSs for Simple Tensed Sentences

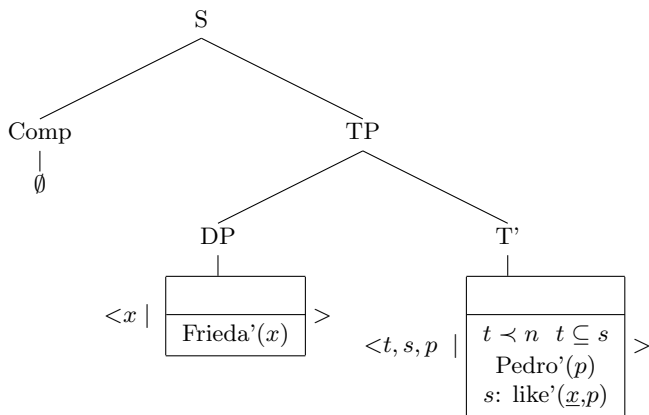

Constructing DRSs for Simple Tensed Sentences

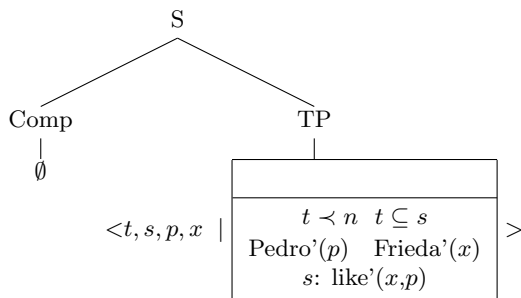

t	s	p	x
$t \prec n \quad t \subseteq s$			
Pedro'(p)		Frieda'(x)	
s: like'(x,p)			

Constructing DRSs for Simple Tensed Sentences

(93)

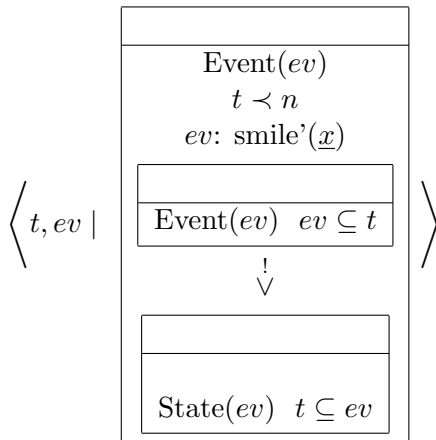

Aspect

(94)

- a. At 18.00 Frieda closed the shop.
- b. At 18.00 Frieda was closing the shop.

(95)

- a. Perfective clauses describe events. Imperfective clauses describe states.
- b. Temporal location times t locate events via the condition ' $e \subseteq t$ ', and states via the condition ' $t \subseteq s$ '.

Constructing DRSs for Simple Tensed Sentences

(96) (lexical entry for the tense feature 'past')

past (tense
feature)

Sel. Restr: eventuality description

Sem.Repr: $\langle ev_{ref}, \dots \mid K \rangle \rightsquigarrow$

$\langle t, ev, \dots \mid K \cup$

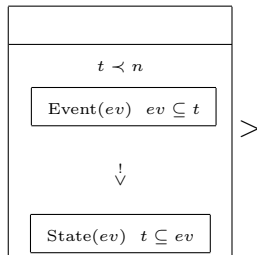

Constructing DRSs for Simple Tensed Sentences

(97)

a. $\langle t, ev \mid$

Event(ev)
$t \prec n$
$ev: \text{smile}'(\underline{x_1})$
Event(ev) $ev \subseteq t$

\rangle

b. $\langle t, e \mid$

$t \prec n$ $e \subseteq t$
$e: \text{smile}'(\underline{x_1})$

\rangle

Constructing DRSs for Simple Tensed Sentences

(98)

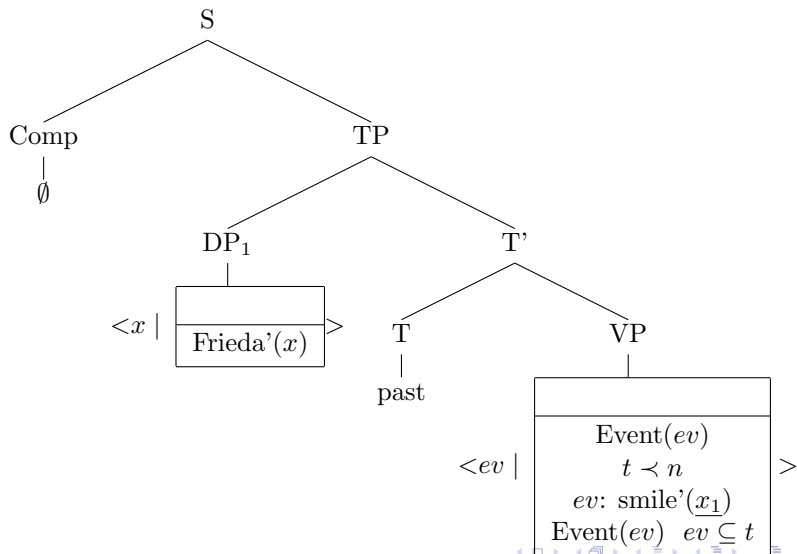

Constructing DRSs for Simple Tensed Sentences

(99)

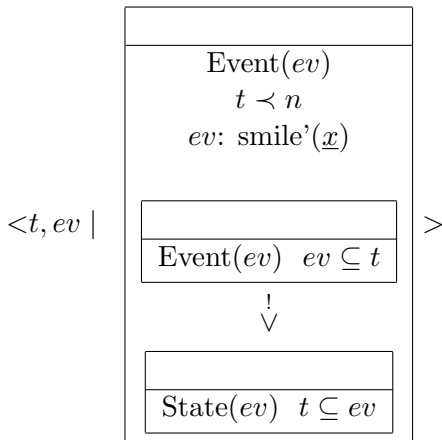

Constructing DRSs for Simple Tensed Sentences

(100)

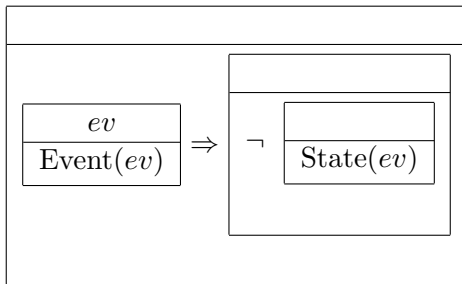

Referential Arguments

(101)

- a. A friend of Mary died.
- b. Mary's mother died.
- c. Mary invited two of her friends.

Referential Arguments

(102)

friend (N, rel.)

nom

x

y

Sel. Restr:

animate

animate

Sem.Repr:

$\langle x \mid \begin{array}{|c|} \hline \phantom{\text{friend}'(x,y)} \\ \hline \text{friend}'(x,\underline{y}) \\ \hline \end{array} \rangle$

Referential Arguments

(103)

cat (N)
x

Sel. Restr:

Sem.Repr:

$\langle x \mid \boxed{\text{cat}'(x)} \rangle$

Referential Arguments

(104)

- a. That morning he cleaned the bathroom. The cleaning was as thorough as any he could remember.
- b. Suzie and Lara climbed Mt. Fuji. The climb took them a day.

Referential Arguments

(105)

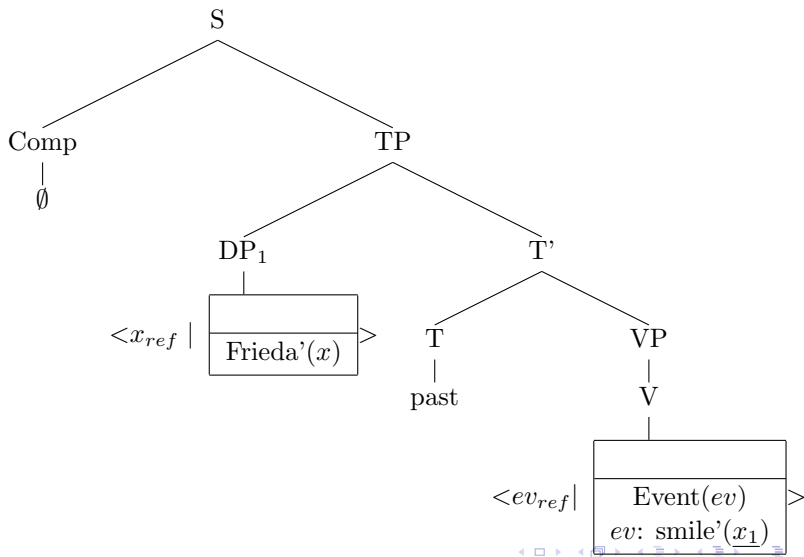

Referential Arguments

(106)

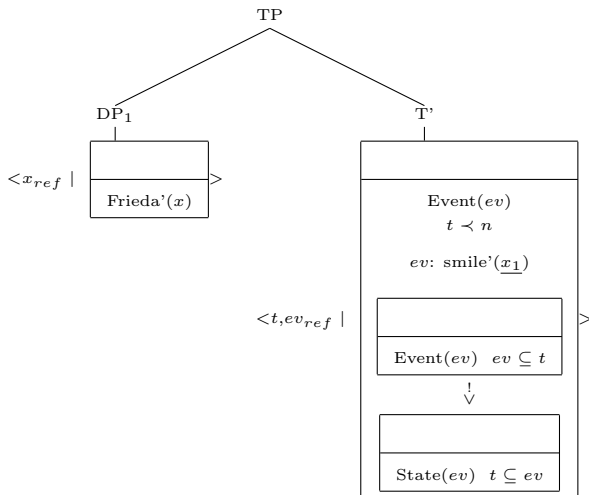

Referential Arguments

(107)

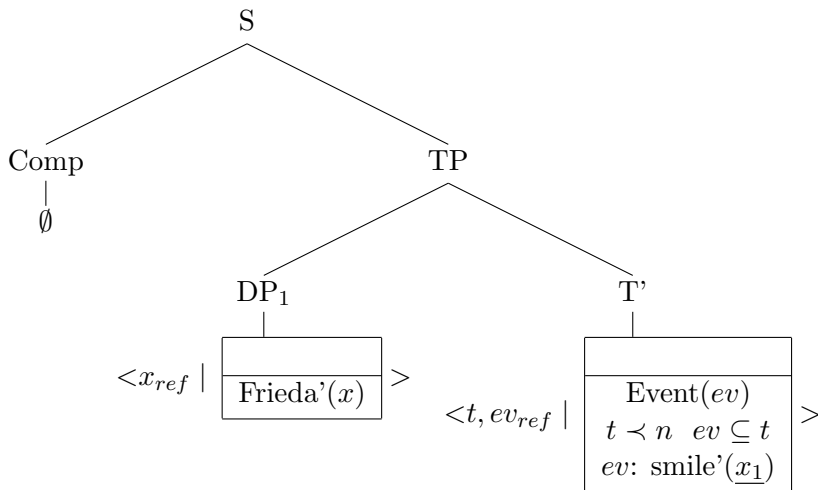

Referential Arguments

(108)

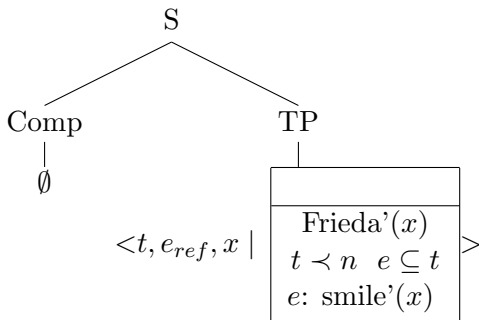

Aspect

(109)

- a. At 18.00 Frieda closed the shop.
- b. At 18.00 Frieda was closing the shop.

Aspect; DRS construction for: 'At 18.00 Frieda closed the shop'

(110)

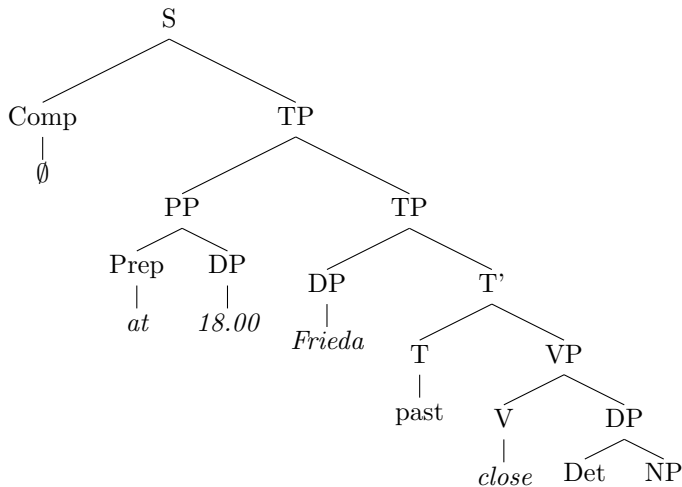

Aspect

(111)

<i>close</i> (V, trans.)	nom	acc
<i>e</i>	<u><i>x</i></u>	<u><i>y</i></u>

Sel. Restr: event animate

Sem.Repr: $\langle e \mid \boxed{\begin{array}{c} \phantom{e: close'(\underline{x}, \underline{y})} \\ e: close'(\underline{x}, \underline{y}) \end{array}} \rangle$

Aspect

(112)

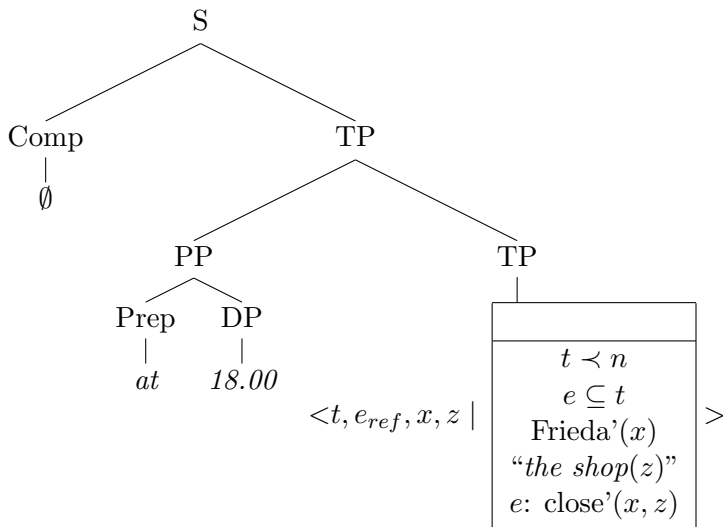

Aspect

(113)

at (Prep)
 ev

acc
 \underline{t}

Sel. Restr:

eventuality

temporal
point

Sem.Repr:

$\langle ev_{ref} \mid$

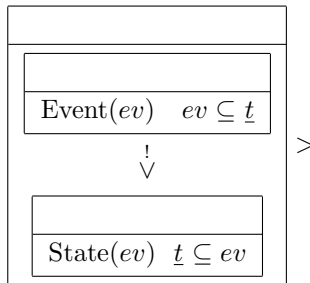

Aspect

(114)

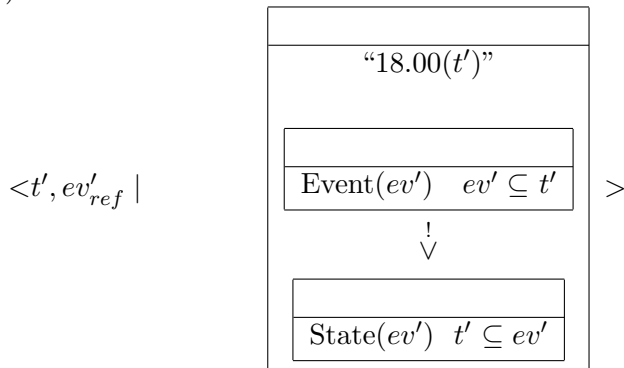

Aspect

(115)

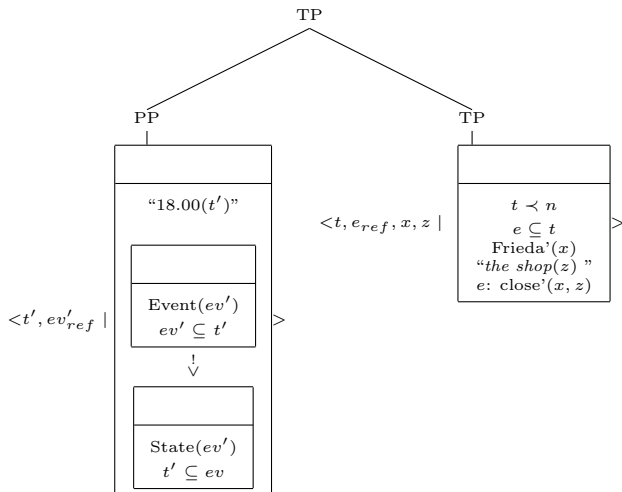

Aspect

(116)

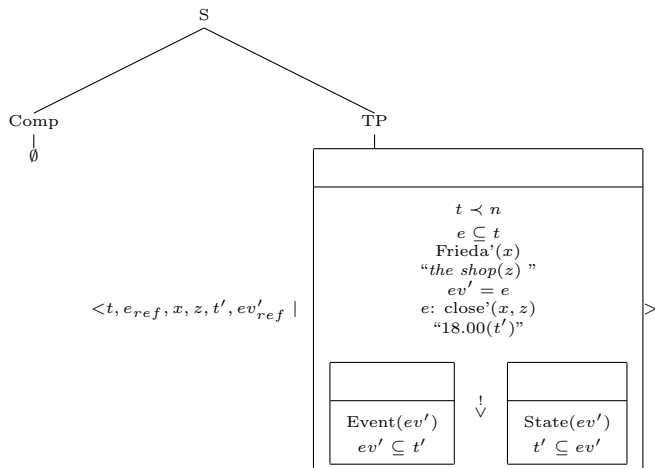

Aspect

(117)

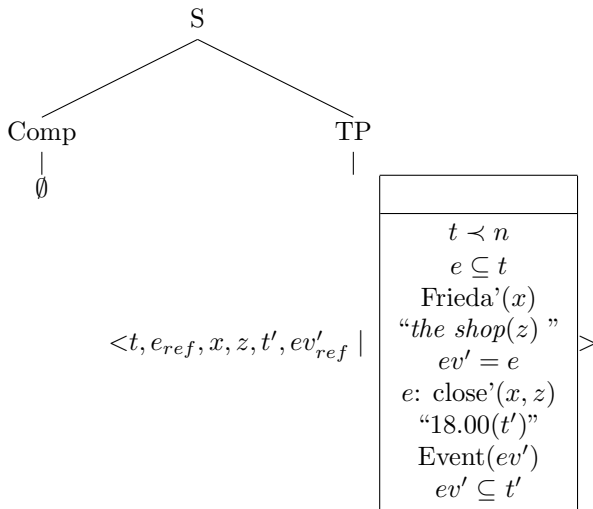

Aspect

(118)

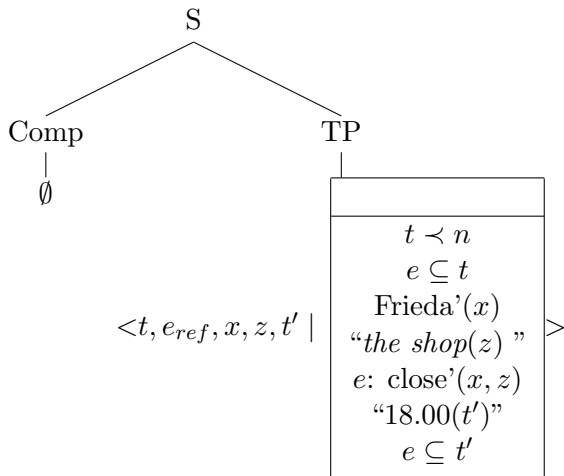

Aspect; DRS Construction for: 'At 18.00 Frieda was closing the shop'

(119)

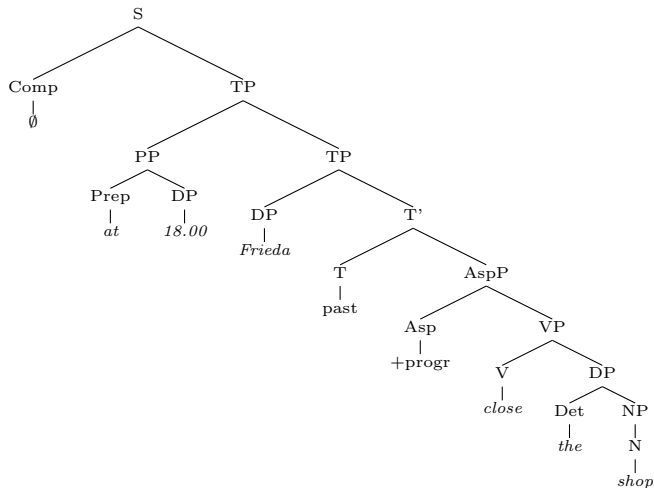

Aspect

(120)

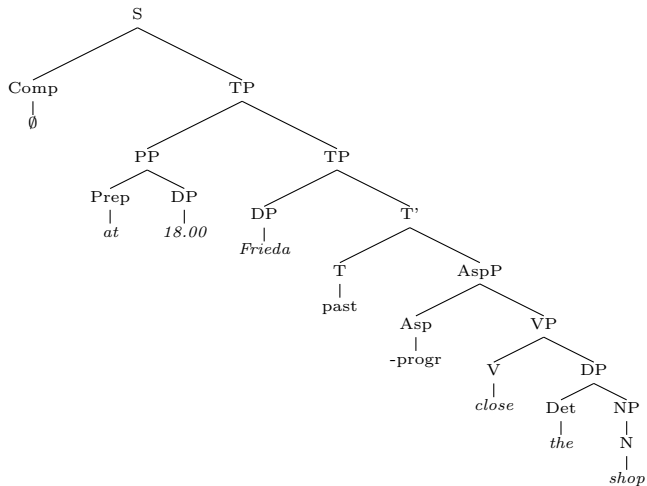

Aspect

(121)

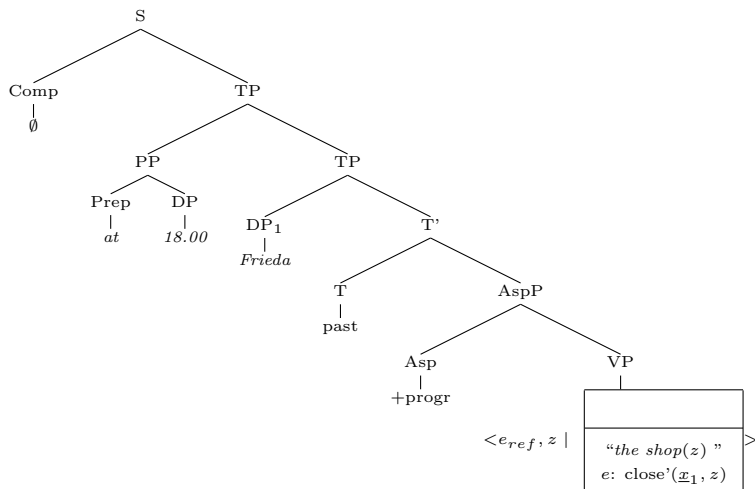

Aspect

(122)

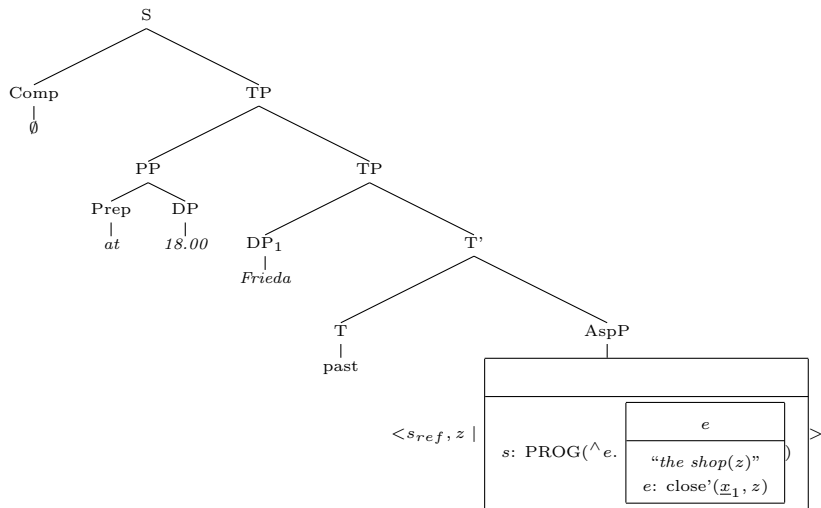

Aspect

(123)

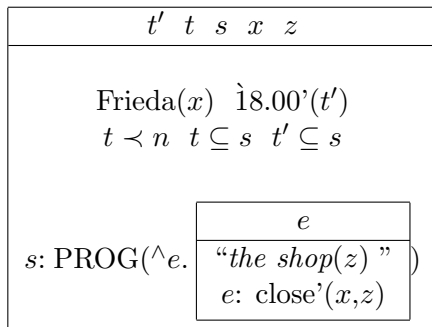

The Imperfective Paradox

(124)a. Frieda was singing.

b. Frieda sang.

c. At 18.00 Frieda was closing the shop.

d. At 18.00 Frieda closed the shop.

(125) The glass was rolling off the table when I caught it.

(126) The old lady was crossing the road when she was hit by a truck.

The Imperfective Paradox

(127)

- a. Frieda was singing.
- b. Frieda sang.
- c. Frieda is singing.
- d. Frieda sings.

(128)

- a. John is sitting in the chair to the left.
- b. John sits in the chair to the left.
- c. The statue is standing in the middle of the square.
- d. The statue stands in the middle of the square.
- e. John is standing in the corner of the living room.
- f. John stands in the corner of the living room.
- g. The book is lying on the table.
- h. The book lies on the table.

The Imperfective Paradox

(129)

- a. * Mary is knowing the answer to this problem.
- b. * John is being six feet tall.

Can progressives of state verbs ever be grammatical?
The examples in (130) seem to indicate that they can be.

(130)

- a. Bennie is just being obnoxious.
- b. Stella is being her usual innocent self again.
- c. Carla is loving her new job.
- d. As long as they are believing you are speaking the truth, there isn't too much you have to worry about.

The Imperfective Paradox

(131) (lexical entry for the aspect feature ‘+prog’)

+prog (aspect feature)

Sel. Restr: event description

Sem.Repr: $\langle e_{ref}, \dots \mid K \rangle \rightsquigarrow$
 $\langle s_{ref}, \dots \mid s:PROG(\wedge e.K \cup \frac{e}{\quad}) \rangle$

The Imperfective Paradox

(132)

e	t
$K(e)$	
$t \subseteq e$	

 \Rightarrow

s
$s: \text{PROG}(\wedge e. K(e))$
$\text{dur}(s) = t$

(133)

s	x		
$s: \text{PROG}(\wedge e.$	<table border="1" style="display: inline-table;"> <tr><td>e</td></tr> <tr><td>$e: \text{sing}'(x)$</td></tr> </table>	e	$e: \text{sing}'(x)$
e			
$e: \text{sing}'(x)$			

 \Rightarrow

e'
$\text{dur}(e') = \text{dur}(s)$
$e': \text{sing}'(x)$

Once more: Trans-sentential Powers of Tense and Aspect Operators

- (134)a. I didn't turn off the stove. (Partee (1973))
- b. When we were closing up the house before setting off on this trip, I didn't turn off the stove.
 - c. On August 5, 1996, when we were closing up the house before setting off on our trip to Alaska, I didn't turn off the stove.
 - d. The worst thing that ever happened to me before going on to a trip was when I was locking up the house to go for four weeks to Alaska. I didn't turn off the stove.

Trans-sentential Powers of Tense and Aspect Operators

(135) (Webber (1988))

- a. When they built the 39th Street bridge, a local architect drew up the plans.
- b. When they built the 39th Street bridge, they used the best materials.
- c. When they built the 39th Street bridge, they solved most of their traffic problems.

Trans-sentential Powers of Tense and Aspect Operators

(136) (Lascarides and Asher (1993))

- a. John fell. Bill helped him to get up.
- b. John fell. Bill pushed him.
- c. John fell. Bill didn't.

(137)a. John fell. Bill had helped him to get up.

- b. John fell. Bill had pushed him.
- c. John fell. Bill hadn't.

Trans-sentential Powers of Tense and Aspect Operators

- (138)a. One of the ten marbles is not in the bag. It is under the sofa.
b. Nine of the ten marbles are in the bag. It is under the sofa.

(139) (Kamp (2019))

- a. I played this slot machine ten times. One time it didn't just swallow my money. It spit out 20 dollars in small change.
b. I played this slot machine ten times. Nine times it just swallowed my money. It spit out 20 dollars in small change.

Trans-sentential Powers of Tense and Aspect Operators

(140)

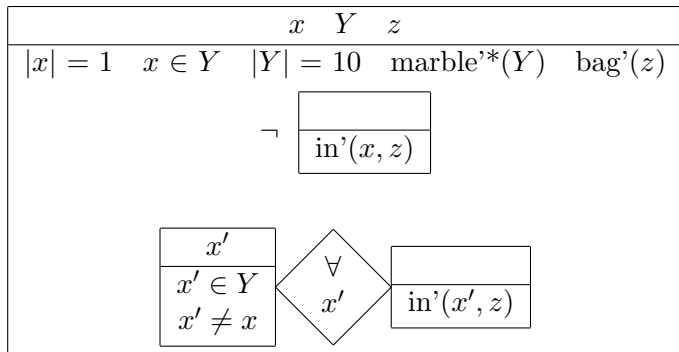

Trans-sentential Powers of Tense and Aspect Operators

(141)

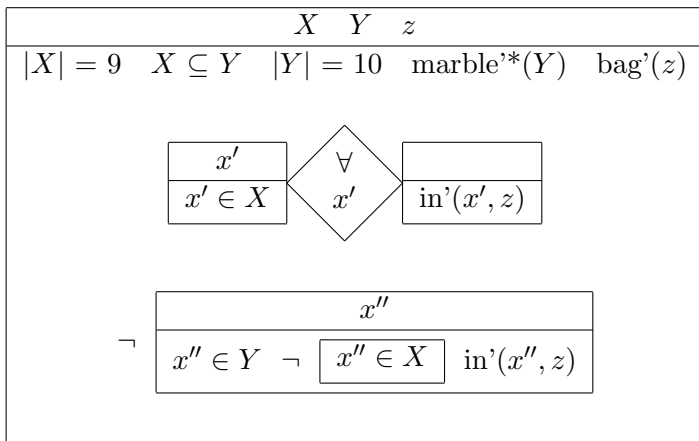

Trans-sentential Powers of Tense and Aspect Operators

(142)

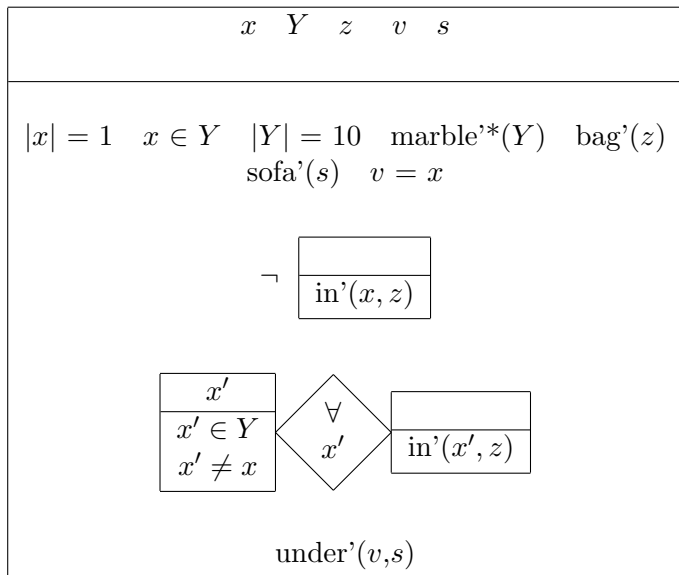

Trans-sentential Powers of Tense and Aspect Operators

(143)a. John proved a well-known conjecture in twenty pages.

b.

e	t	j	y
$t \prec n$	$e \subseteq t$	John'(j)	conjecture'(y) well-known'(y)
e : prove'(j,y)			
'in-twenty-pages'(e)			

Logical Form Approaches: Models and Ontology

- Logical Form Approaches assign meaning by assigning *Logical Forms*.
- Logical Forms are terms from some given *Logical Form Formalism*.
- Logical Form Formalisms are formal languages that are given by
 - (i) a definition of syntactic well-formedness and
 - (ii) a model theory for the well-formed expressions of the formalism.

Logical Form Approaches: Models and Ontology

- Logical Forms ‘transfer’ their model-theoretically fixed semantics to the natural language expression to which they are assigned.
- Logical Form Formalisms can come with certain *ontological commitments*
- These commitments can be made both at the level of the syntax of the LFF or at the level of its model theory.

Ontological commitments that are made at the level of syntax are ‘inherited’ by the model theory.

But not conversely.

Logical Form Approaches: Models and Ontology

- Many ontological decisions can be made at the level of the model theory for the LFF without any direct important consequences for its applications to natural language semantics.

This endows the LFF approach with the advantage of offering a framework within which communities with different ontological, logical and semantic concerns can pursue their own research agendas without getting too much in each others' way.

- A good illustration of this: the logical, ontological and semantic issues related to time.

Logical Form Approaches: Models and Ontology

Another Partee example (from Partee (1984)).

(144) John got up, went to the window, and raised the blind.

It was light out.

He pulled the blind down and went back to bed.

He wasn't ready to face the day. He was too depressed.

Logical Form Approaches: Models and Ontology

(145)

e_1	e_2	e_3	e_4	e_5	s_1	s_2	s_3
$e_1 < e_2 < e_3 < e_4 < e_5$							
e_1 : John get up							
e_2 : John go up to the window							
e_3 : John raise the blind							
e_4 : John pull the blind down							
e_5 : John go back to bed							
$s_1 \text{ O } e_3$ $s_2 \text{ O } e_5$ $s_3 \text{ O } e_5$							
s_1 : It be light out							
s_2 : John not be ready to face the day							
s_3 : John be too depressed							

Logical Form Approaches: Models and Ontology

(146)

e_1	t_1	e_2	t_2	e_3	t_3	s_1	t_4	e_4	t_5	e_5	t_6	s_2	t_7	s_3	t_8
$t_1 \prec n$	$e_1 \subseteq t_1$	$t_2 \prec n$	$e_2 \subseteq t_2$	$e_1 \prec e_2$	$t_3 \prec n$	$e_3 \subseteq t_3$	$e_2 \prec e_3$	$t_4 \prec n$	$t_4 \subseteq s_1$	$e_3 \subseteq s_1$	$t_5 \prec n$	$e_4 \subseteq t_5$	$e_3 \prec e_4$	$t_6 \prec n$	$e_5 \subseteq t_6$
$e_4 \prec e_5$	$t_7 \prec n$	$t_7 \subseteq s_2$	$e_5 \subseteq s_2$	$t_8 \prec n$	$t_8 \subseteq s_3$	$t_7 \subseteq s_3$	$e_5 \subseteq s_3$								

e_1 : John get up
 e_2 : John go up to the window
 e_3 : John raise the blind
 s_1 : It be light out
 e_4 : John pull the blind down
 e_5 : John go back to bed
 s_2 : John not be ready to face the day
 s_3 : John be too depressed

Logical Form Approaches: Models and Ontology

(147)(time structure, events and states of M)

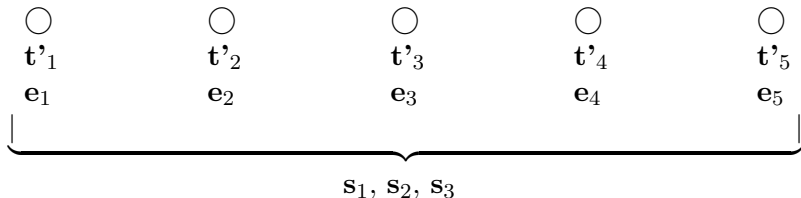

Logical Form Approaches: Models and Ontology

(148) But Philip ceased to think of her a moment after he **had settled down** in his carriage. [...]. He **had written** to Mrs. Otter, the massière to whom Hayward **had given him** an introduction.

(Somerset Maugham, *Of Human Bondage*)

(149) John sat down by the fire, exhausted. **Yesterday** had been one of the toughest days he could remember. But **now/today** things were better. And they would be even better **tomorrow**.

Logical Form Approaches: Models and Ontology

(??b) John proved a well-known conjecture in twenty pages. Mary had proved it in ten pages.

(143.b)

e	t	j	y
$t \prec n$	$e \subseteq t$	John'(j)	conjecture'(y) well-known'(y)
e : prove'(j,y)			
'in-twenty-pages'(e)			

(150) <{

$t''?$	TP_{pt} ,	$v?$	$an.pr.3d.sg.$ },	>
$t'' \prec n$		non-human(v)		

e'	t'	m
Mary'(m)		
$TP_{pt} := t''$		
$t' \prec TP_{pt}$ $e' \subseteq t'$		
e' : prove'(m,v)		
'in-ten-pages'(e')		

Logical Form Approaches: Models and Ontology

(151)a.

e'	t'	m	t''	v
				Mary'(m)
				$TPpt := t''$
			$t' \prec TPpt$	$e' \subseteq t'$
				$e': \text{prove}'(m,v)$
				'in-ten-pages'(e')
			$t'' = dur(e)$	$v = y$

b.

e	t	j	y	e'	t'	m	t''	v
$t \prec n$	$e \subseteq t$			John'(j)				well-known'(y)
				$e : \text{prove}'(j,y)$				
				'in-twenty-pages'(e)				
							$t'' = dur(e)$	
					$t' \prec t''$			
					$e' \subseteq t'$			
						Mary'(m)		$v = y$
					$e': \text{prove}'(m,v)$			
					'in-ten-pages'(e')			

Logical Form Approaches: Models and Ontology

$e \ t \ a \ e' \ t' \ y \ v \ u \ s \ t'' \ w \ t''' \ e'' \ r$

$t \prec n \quad e \subseteq t \quad \text{Alan}'(a) \quad \text{wife}'(y,v)$

$e : \text{saw}'(u,y)$

$t' \prec n \quad e' \subseteq t'$

$e' : \text{open-one's-eyes}'(a)$

$e' \prec e$

(153)

$t'' = \text{dur}(e') \quad t'' \subseteq s$

$s : \text{'be-standing-beside-}w\text{'s-bedsite''}(y)$

$v = a \quad u = a \quad w = a$

$t''' \prec n \quad e'' \subseteq t''' \quad r = y$

$e'' : \text{smile}'(r)$

$e \prec e''$

Logical Form Approaches: Models and Ontology

(2.b) When Alan opened his eyes he saw his wife who was standing by his bedside. She was smiling.

(154)

e	t	a	e'	t'	y	v	u	s	t''	w
$t \prec n$	$e \subseteq t$	Alan'(a)	wife'(y,v)							
		e : see'(u,y)								
		$t' \prec n$	$e' \subseteq t'$							
		e' : open-one's-eyes'(a)								
		$e' \prec e$								
		$t'' = dur(e')$	$t'' \subseteq s$							
		s : be-standing-beside-w's-bedside'(y)								
		$v = a$	$u = a$	$w = a$						

Logical Form Approaches: Models and Ontology

(155)

e	t	a	e'	t'	y	v	u	s	t''	w	t'''	s'	r
	$t \prec n$		$e \subseteq t$						$\text{Alan}'(a)$				$\text{wife}'(y,v)$
									$e : \text{saw}'(u,y)$				
				$t' \prec n'$					$e' \subseteq t'$				
									$e' : \text{open-one's-eyes}'(a)$				
									$e' \prec e$				
									$t'' = \text{dur}(e')$			$t'' \subseteq s$	
									$s : \text{'be-standing-beside-}w\text{'s-bedside''}(y)$				
									$v = a$	$u = a$		$w = a$	
									$t''' \prec n$		$t''' = \text{dur}(e)$	$t''' \subseteq s'$	$r = y$
												$s' : r \text{ be-smiling}$	

Past Perfects: Tense or Tense + Aspect?

(156) John reflected on how the day had started.

He had got up, had gone to the window, and had raised the blind.

It had been light out.

He had pulled the blind down and had gone back to bed.

He hadn't been ready to face the day. He had been too depressed.

Past Perfects: Tense or Tense + Aspect?

- (157)a. I played this slot machine ten times. One time it didn't just swallow my money. It spit out 20 dollars in small change.
- b. I played this slot machine ten times. Nine times it just swallowed my money. It spit out 20 dollars in small change.

(158)

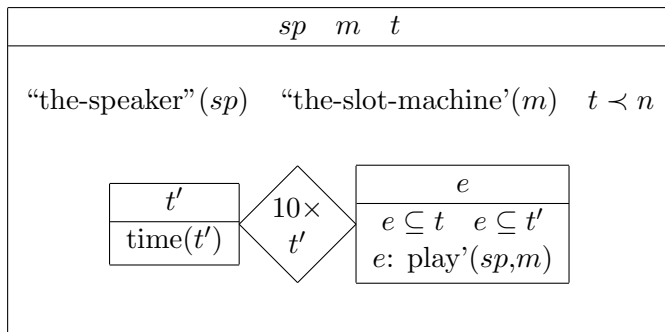

Past Perfects: Tense or Tense + Aspect?

(159)

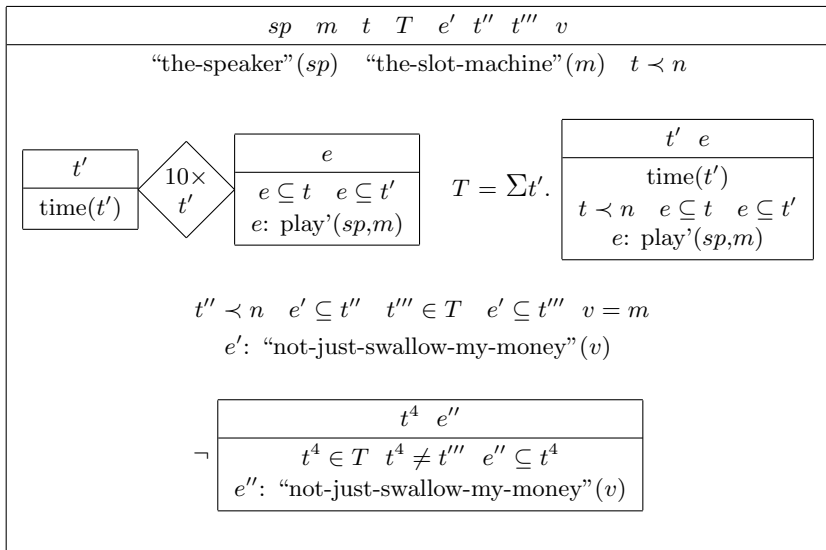

Past Perfects: Tense or Tense + Aspect?

(160)

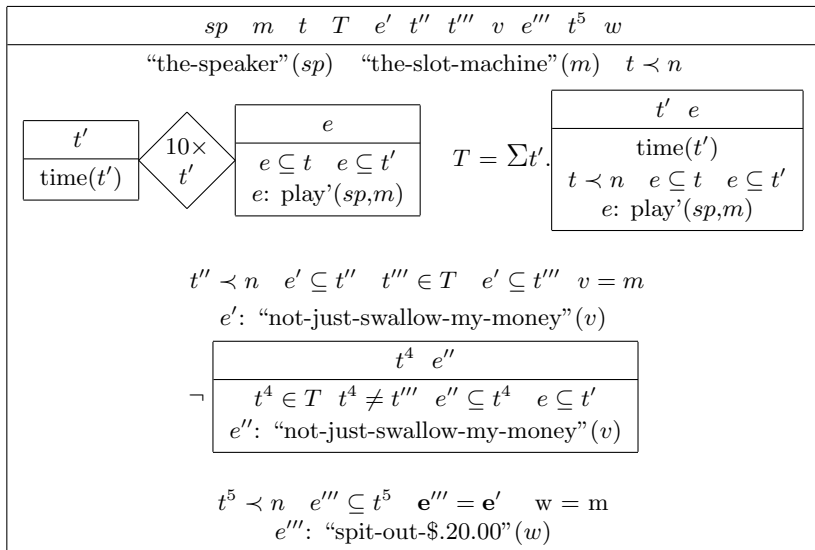

Models and Ontology

(161) (Definition of models for the new DRS-language (beginning))

A *model* for $L_{DRS,t}$ is a tuple $M = \langle T, EV, \preceq_m, U, I \rangle$, where:

- (i) T is a time structure $\langle T, \prec_t \rangle$, with \prec_t a linear order of T ;
- (ii) EV is an event structure $\langle EV, Dur, \text{Event}, \text{State} \rangle$, with Dur a function from EV into the set of intervals of T , and Event and State subsets of EV that are mutually exclusive and jointly exhaustive.
- (iii) U is a set which includes EV , T and $\text{INT}(T)$ (where $\text{INT}(T)$ is defined from T along the lines indicated above).

Models and Ontology

(161) (Definition of models for the new DRS-language (continued))

(iv) \preceq_m is a weak partial ordering (i.e. \preceq_m is reflexive and transitive) with the additional property that if $ev \preceq_m ev'$ and $ev' \preceq_m ev$, then $ev = ev'$, and with a partial sum \oplus as described above.

(v) I is a function that assigns each predicate constant of $L_{DRS,t}$ an appropriate extension. More specifically:

(a) for the temporal predicate ' \prec_t ' of $L_{DRS,t}$ $I(\prec_t) = \prec_{t,M}$ (where $\prec_{t,M}$ is the second component of T_M).

Note that this stipulation also fixes the interpretation of \subseteq and $\supset\subset$, which are definable in terms of \prec_t .

Also $I(dur) = Dur$.

Models and Ontology

- (161) (Definition of models for the new DRS-language (continued))
- (b) for each constant V' that translates an event/state verb V with n non-referential arguments (where $n \geq 0$) $I(V')$ is a set of $n+1$ -tuples $\langle e/s, a_1, \dots, a_n \rangle$, where e/s is an event $\in E_M$ /state $\in S_M$ and a_1, \dots, a_n are members of U_M .
 - (c) For each DRS constant P' that translates a non-verbal n -place predicate P ($n \geq 1$) $I(P')$ is a set of n -tuples $\langle a_1, \dots, a_n \rangle$, where a_1, \dots, a_n are members of U_M .
 - (d) For each constant c' of $L_{DRS,t}$ that functions as a proper name $I(c')$ is a member of U_M .

Temporal Variability in the Extensions of non-verbal Predicates

(162)

- a. When my wife and I first met, she was married to Nicholas Parker.
- b. In 2001 my wife and I went on a cruise. That was the end of our marriage. We got divorced a year later.

(163)

- a. When she said that, he became angry.
- b. In the autumn the leaves turn green.
- c. She made him furious.
- d. She went into the house.
- e. She is no longer with him.
- f. She is back in London.
- g. He is quiet again.

Temporal Variability in the Extensions of non-verbal Predicates

- One of the original examples of a noun that is used to describe entities that no longer satisfy it at the time of utterance is this one from Muvet En;

(164) The fugitives are back in jail

This example has been seen as raising a further problem:

Is *fugitive* reinterpreted in (164) as something like *recently fugitive* or *former fugitive* and this predicate is then evaluated at the utterance time?

Or is *fugitive* unmodified (and thus taken to entail that you are not in the place from which you fled) and evaluated at some time preceding the utterance time?

Temporal Variability in the Extensions of non-verbal Predicates

- Compare in this connection the sentences in (165)

(165)

- a. The fugitives have been caught.
- b. The fugitives were caught.

(165.c) carries a strong suggestion that it is about persons who were fugitives at the time they were caught

(though this of course entails that they are former fugitives at n).

For (165.b) this may be less clear. See the discussion of the Perfect in Section 3.8.

- But note: either way of interpreting these sentences presupposes that *fugitive* can change its extension with time.

Other Tenses: The Simple Future Tense

(166)

- a. Louise will go to Paris on Sunday.
- b. Louise will love Paris.
- c. Louise will be visiting Paris.

(167)

- a. There will be a sea battle tomorrow.
- b. There was a sea battle yesterday.

Other Tenses: The Simple Future Tense

(168) (lexical entry for the tense feature 'fut')

fut (tense
feature)

Sel. Restr: eventuality description

Sem.Repr: $\langle ev_{ref}, \dots \mid K \rangle \rightsquigarrow$

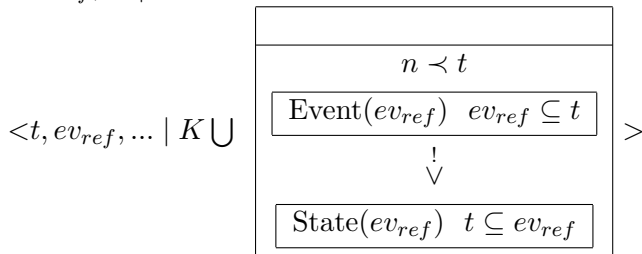

Other Tenses: The Present Tense

(169)

- a. Louise loves Paris.
- b. Louise is visiting Paris.
- c. Louise visits Paris.
- d. Louise is writing a letter/two letters/several letters/some letters.
- e. Louise writes a letter/two letters/several letters/some letters/the letter.
- f. Louise writes letters.
- g. Louise writes several letters a day.
- h. Louise plays the violin.
- i. Louise is eating an apple.
- j. Louise eats an apple.
- k. Louise eats an apple a day.
- l. Occasionally Louise eats an apple.

Other Tenses: The Present Tense

- (170)
- a. I am hearing a nightingale.
 - b. I hear a nightingale.
 - c. I promise to submit the paper by Friday.
 - d. I am promising to submit the paper by Friday.
 - e. And now the moment has come that we have all been waiting for: The Queen steps forward and cuts the ribbon. The bridge is open for general use.

(171) The Standard Use of the Present Tense is restricted to input representations with Imperfective Aspect.

Other Tenses: The Present Tense

$$(172) \langle e_{ref}, p \mid \begin{array}{|c|} \hline \\ \hline Paris'(p) \\ \hline e : visit'(\underline{x}, p) \\ \hline \end{array} \rangle$$

HAB then turns this representation into the one in (173).

$$(173) \langle s_{ref}, p \mid \begin{array}{|c|} \hline \\ \hline s : HAB(\wedge e. \begin{array}{|c|} \hline e \\ \hline Paris'(p) \\ \hline e : visit'(\underline{x}, p) \\ \hline \end{array}) \\ \hline \end{array} \rangle$$

Other Tenses: The Present Tense

- It tends to be much harder to get habitual readings for simple past tense sentences.

(174)

- a. Louise ate an apple.
- b. Louise eats an apple. (= (169.j))
- c. He made dinner. She did the dishes.
- d. He makes dinner. She does the dishes.

The use of *would* or *used to* is often needed to make habitual readings explicit.

(175)

- a. He would make dinner. She would do the dishes.
- b. He used to make dinner. She used to do the dishes.
- c. Louise would eat an apple.
- d. Louise used to eat an apple.

Other Tenses: The Historical Present

(176)

So I go up to this house and ring the bell. And at first nothing happens. And then I ring the bell again and the door flings open and a bullet whistles past my head. 'What do you want?' the guy says. 'I am from the Democratic Party' I say, we are trying to talk to people in this neighborhood.' 'Get off my property' the guy says, 'or you'll find out I am a better shot than you thought.' So I back off and it is only after I am past the gate again that I dare to turn my back on him.

Other Tenses: Futurite Uses of the Present Tense

(177)

- a. The sun rises at 7.42 tomorrow.
- b. The train for Paris leaves at 12.44.
- c. Chelsea plays Arsenal next Sunday.

In English future-denoting uses of the Present Tense are restricted.
(178.a) cannot be used to express the natural interpretation of (178.b).

(178)

- a. He will take the job, but he will ask them if he can start a little later.
- b. He takes the job, but he asks them if he can start a little later.

Other Tenses: the Present Tense

- A ‘rump’ entry for the Present Tense.

(179) (lexical entry for the tense feature ‘pres’)

pres (tense
feature)

Sel. Restr: state description

Sem.Repr: $\langle ev_{ref}, \dots \mid K \rangle \rightsquigarrow$

$$\langle t, ev_{ref}, \dots \mid K \cup \left\{ \begin{array}{l} t \subseteq n \\ t \subseteq ev \end{array} \right\} \rangle$$

Perfects

- The following examples show that the Perf projection level must come between the projection levels of Asp and T.

(180)

- a. Frieda has/had/will have been closing the shop.
 - b. * Frieda is/was/will be having closed the shop.
- English Present Perfects of ‘target state’ VPs like *leave the house* are said to require that the target state still holds at the time of utterance.

Do you see a difference between (181.a) and (181.b)?

(181)

- a. Frieda left the house. But she has come back.
- b. Frieda has left the house. But she has come back.

Perfects

(182) Frieda had been closing the shop.

(183)

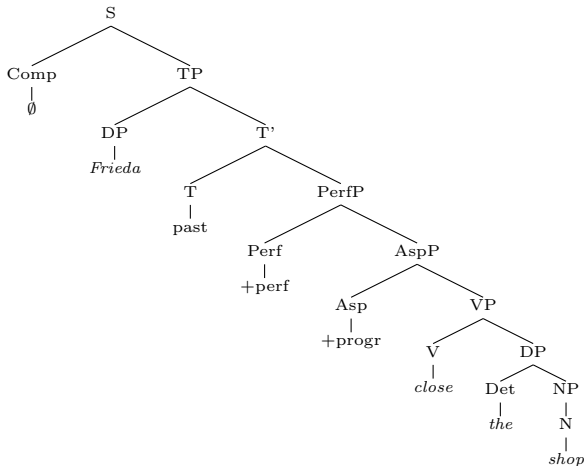

Perfects

(184) Frieda has closed the shop.

(185)

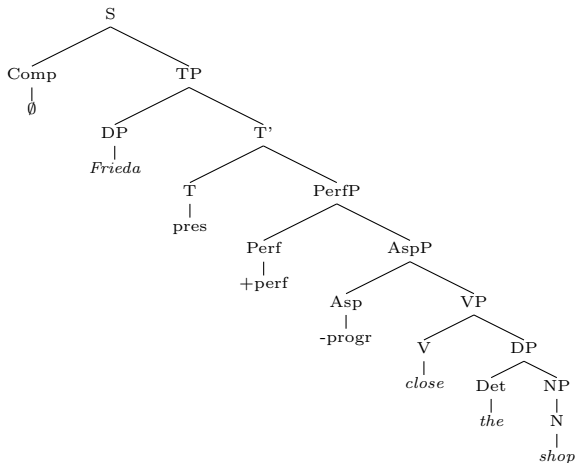

Perfects

(186)

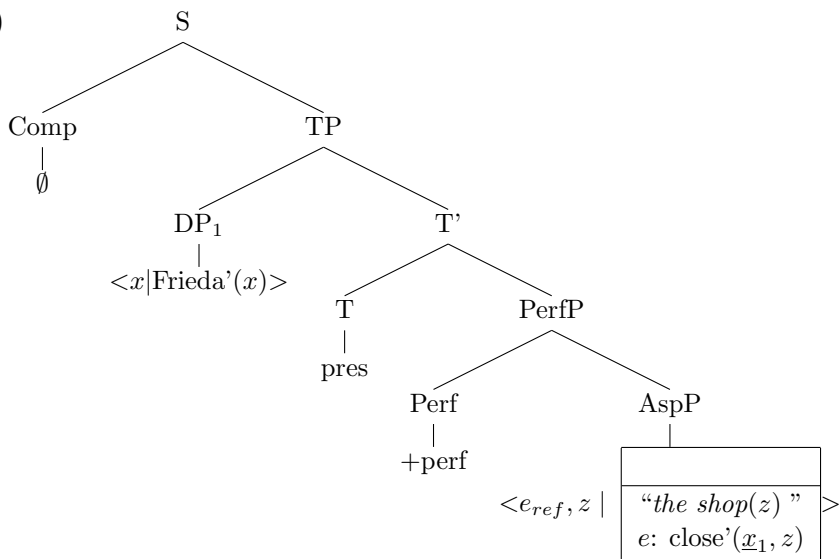

Perfects

(187)

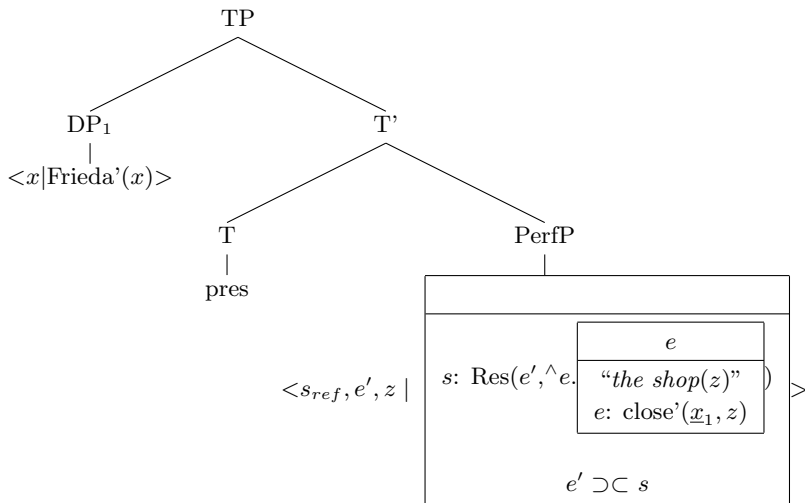

Perfects

(188)

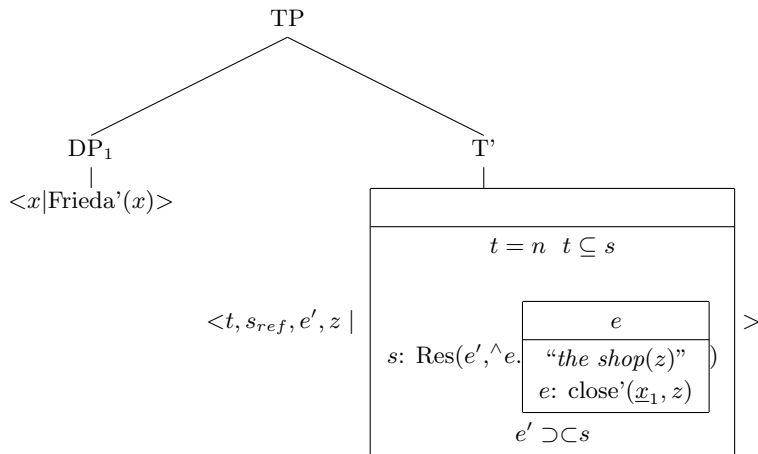

Perfects

(189)

$t \quad s \quad e' \quad z \quad x$				
$t = n \quad t \subseteq s$ Frieda'(x)				
$s: \text{Res}(e', \wedge e.$	e			
	"the shop(z)"			
	$e: \text{close}'(x, z)$ $e' \supset \subset s$			
)				

$t \quad s \quad e' \quad z \quad x$				
$t = n \quad t \subseteq s$ Frieda'(x)				
$e': \text{close}'(x, z)$ res(s, e')				
$e' \supset \subset s$				

Perfects

(190)

- a. Mary has known this since yesterday.
- b. Mary knows this since yesterday.
- c. Mary knew this since yesterday.
- d. Since the first time they met he has loved her.
- e. Since last week Mary has been sick.
- f. Since nine o'clock this morning Mary has been running.
- g. Since nine o'clock this morning Mary has run.

Perfects

(191) (lexical entry for the feature ‘+perf’, beginning)

+perf (perf
feature)

Sel. Restr: event description

Sem.Repr:

(i) if K is not a target state event description (i.e. if the input representation is marked -target state), then

$\langle ev_{ref}, \dots \mid K \rangle \rightsquigarrow \langle s_{ref}, ev, \dots \mid$

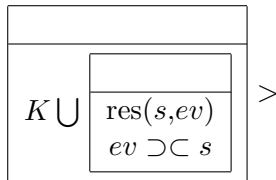

Perfects

(ii) if K is a target state description (i.e. if the input representation is marked +target state), then

$$\langle ev_{ref}, \dots | K \rangle \rightsquigarrow$$

$$\langle s_{ref}, ev', \dots |$$

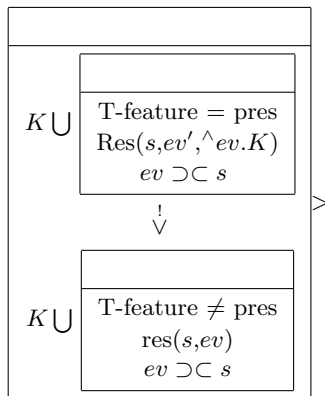

Perfects

(192) (simplified lexical entry for the feature ‘+perf’)

+perf (perf
feature)

Sel. Restr: event description

Sem.Repr: $\langle ev_{ref}, \dots \mid K \rangle \rightsquigarrow$

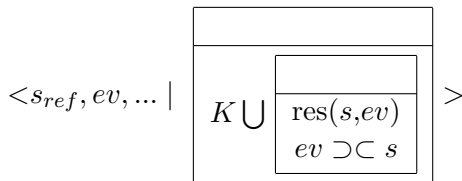

Perfects

(193) Nixon has died.

(194) A: Why are you out of breath?

- B:
- (i) I have been running.
 - (ii) I was running.
 - (iii) I have run.
 - (iv) I ran.

Tense and Nominal Quantification

(195) Every philosopher slept.

Even the simplest sentences with nominal quantifiers now have to deal with the scope interactions between (i) the nominal quantifier Q , (ii) the eventuality described by the verb (in (195) this is an event e) and (iii) its location time t .

Here are some possible scope relations for these three elements:

(196)

- (i) $Q > t > e$.
- (ii) $t > Q > e$.
- (iii) $t > e > Q$.

(Here Q stands for the quantifier expressed by *every philosopher*.)

Tense and Nominal Quantification

(197)

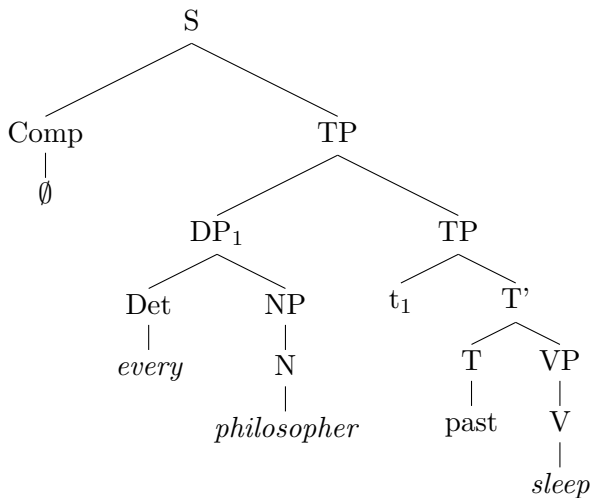

Tense and Nominal Quantification

(198)

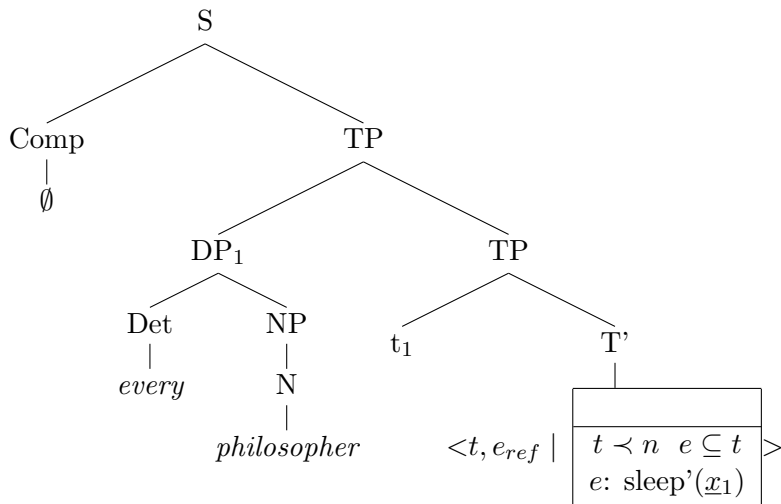

Tense and Nominal Quantification

(199)

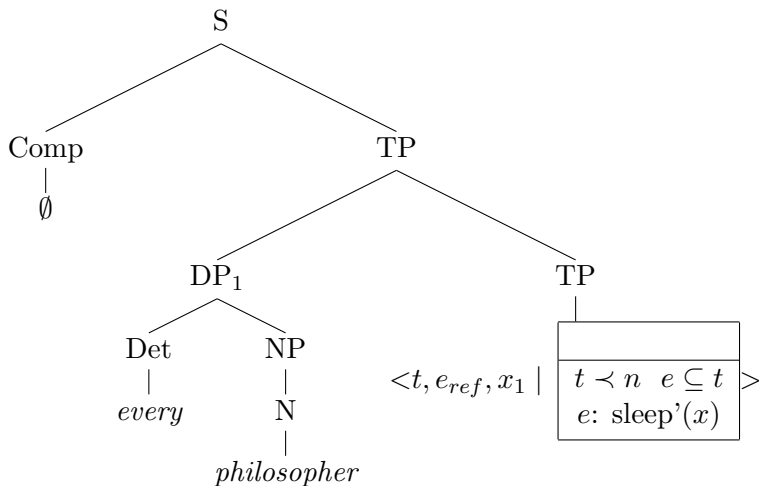

Tense and Nominal Quantification

(200)

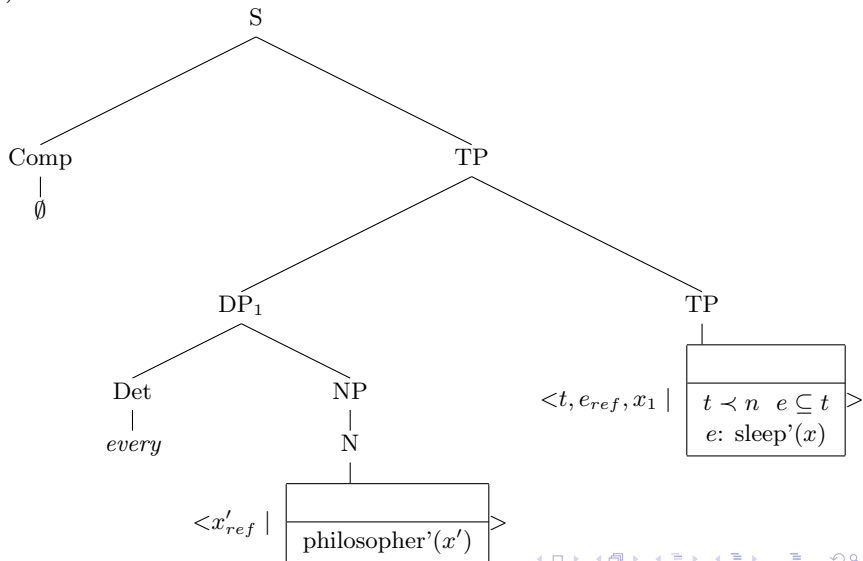

Tense and Nominal Quantification

(201)

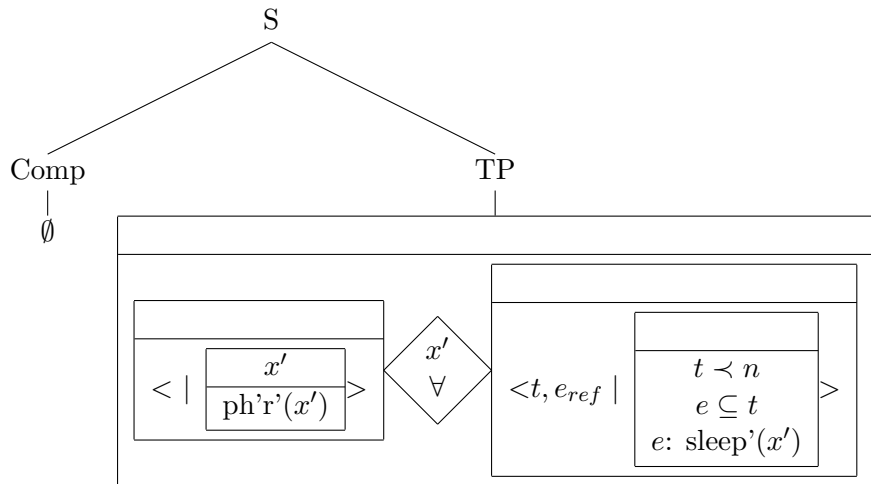

Tense and Nominal Quantification

(202)

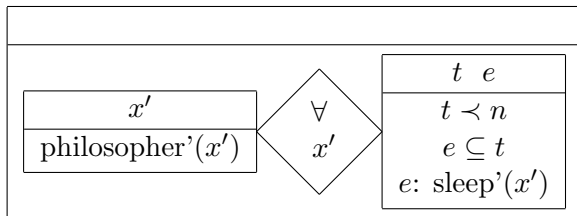

Tense and Nominal Quantification

(203) Lexical entry for the determiner *every* (preliminary)

every (Determiner)

Sel. Restr:

Sem.Repr:

$\langle x_{ref}, .. | K \rangle \rightsquigarrow$

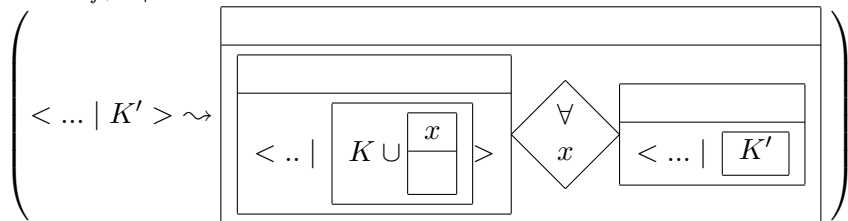

Tense and Nominal Quantification

(204)

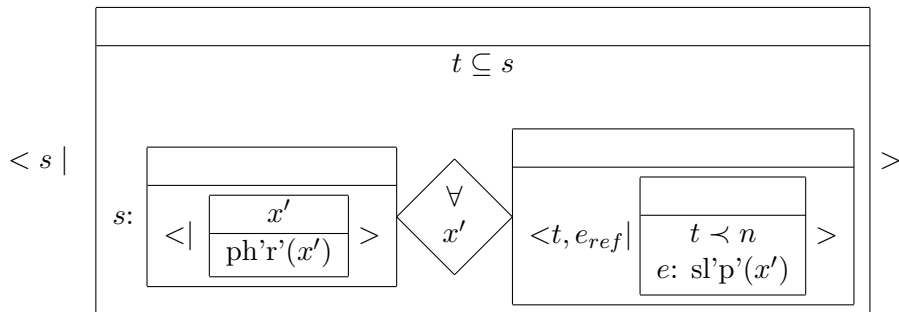

Tense and Nominal Quantification

(205)

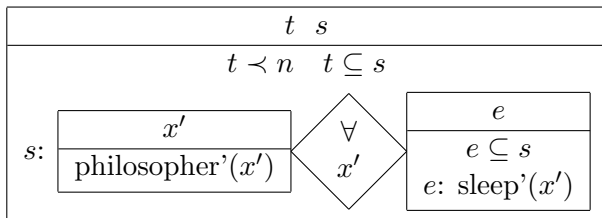

Tense and Nominal Quantification

(206) Lexical entry for the determiner *every* (modified)

every (Determiner)

Sel. Restr:

Sem.Repr:

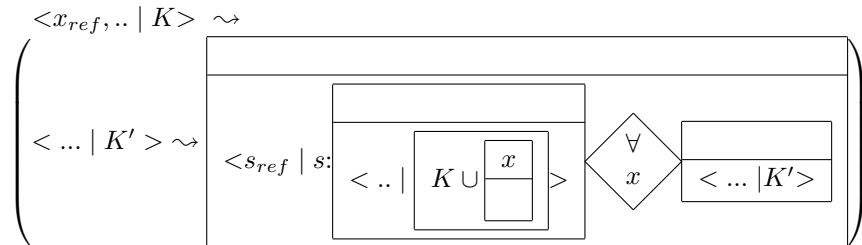

Indefinites

- We look at just one example, the first sentence of the donkey discourse

(32) Pedro owns a donkey. He beats it.

Indefinite DPs will be treated here as ‘indefinite descriptions’, in the spirit of dynamic theories like DRT.

In our set-up this means the following:

- (i) In the syntax indefinite DPs are not QR-ed.
- (ii) When the NP representation is combined with the indefinite determiner to form the representation of the DP, the NP representation is passed up unaltered to the DP node.

This is illustrated in the next three slides.

Indefinites

(207)

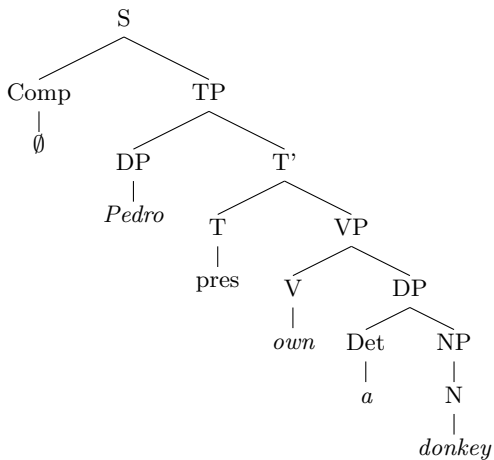

Indefinites

Here we give just the DRS construction for the LF in (207).

(208)

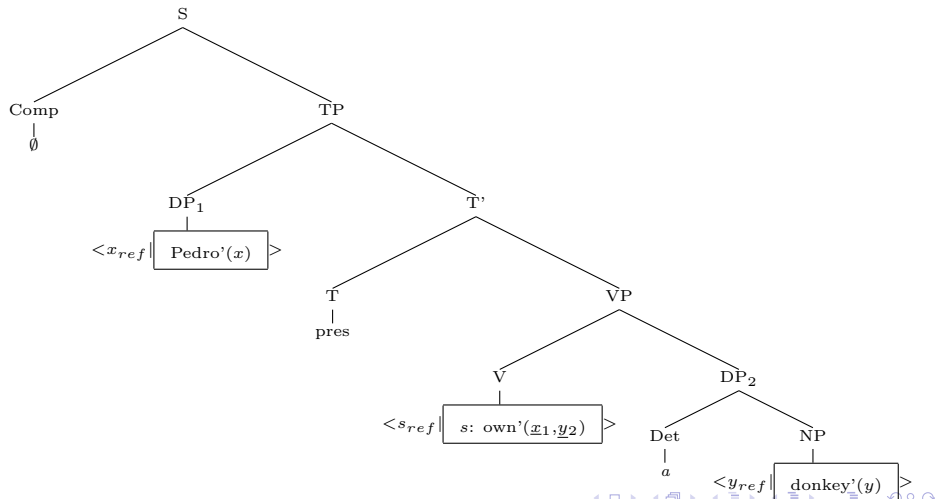

Indefinites

(209)

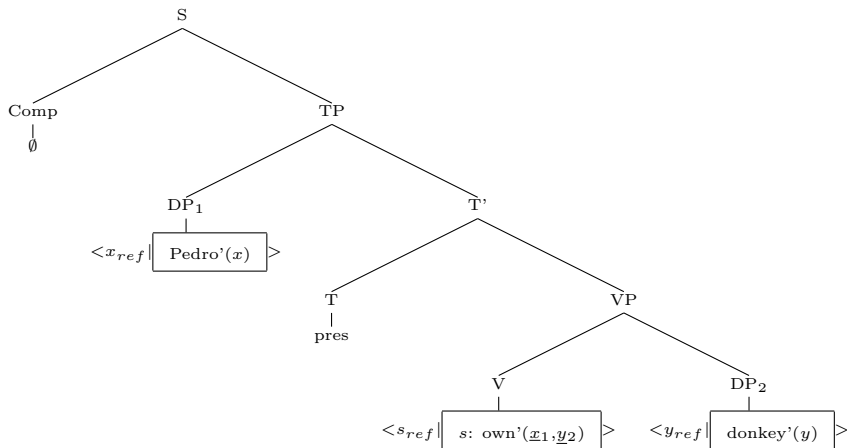

Indefinites

- Normally, indefinite DPs whose determiner is *a* take ‘local’ scope.
(This is so in particular when the indefinite is short and simple.)

In the terms of our approach this means that the dref introduced by an indefinite DP is placed in the Universe of the DRS from the NP representation with which the determiner is combined.

- Indefinites can also be used ‘specifically’.

Such indefinites get ‘wider-than-local’ scope interpretations (unless the local scope is already maximal).

Their drefs get placed in higher DRS Universes, usually in that of the main DRS.

We will ignore specific uses here and only consider the ‘local scope’ interpretation of indefinite DPs.

Indefinites

- The most convenient way over-all to give an indefinite local scope is to insert its dref into the ‘local’ Universe as soon as possible.

This is when the DP’s referential argument of the indefinite gets inserted into its argument slot.

In the present example this occurs when the direct object DP is combined with the semantic representation of the verb to form the representation of the VP.

(N.B. The construction algorithm must be able to recognize the referential argument of the DP as the referential argument of an indefinite.)

We could introduce more notation to make this explicit. But we don’t want to introduce additional notation at this point, so we leave this as a detail for further implementation.)

Indefinites

(210)

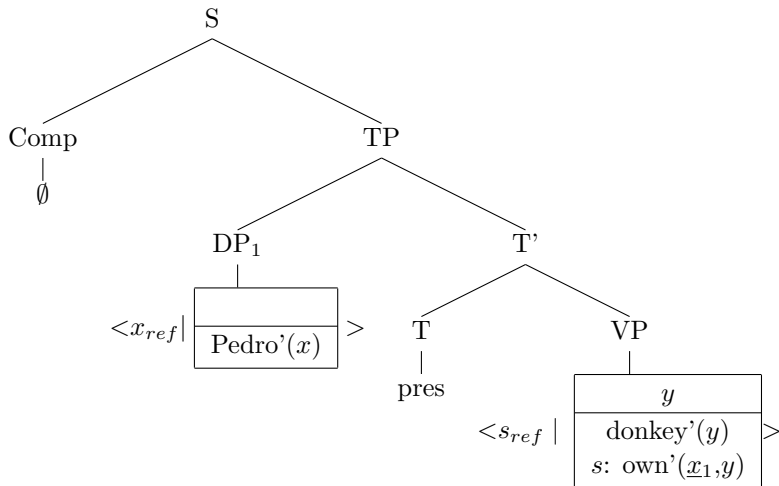

Indefinites

(211)

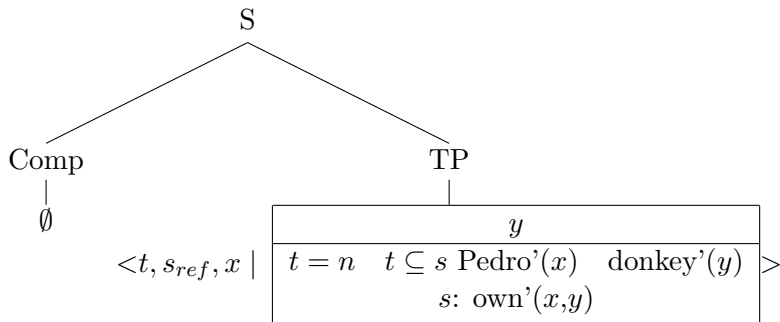

Indefinites

$t \quad s \quad x \quad y$

$t = n \quad t \subseteq s$
Pedro'(x) donkey'(y)
 $s: \text{own}'(x,y)$

Relative Clauses

(212) Pedro knew a farmer who owned a donkey.

(213)

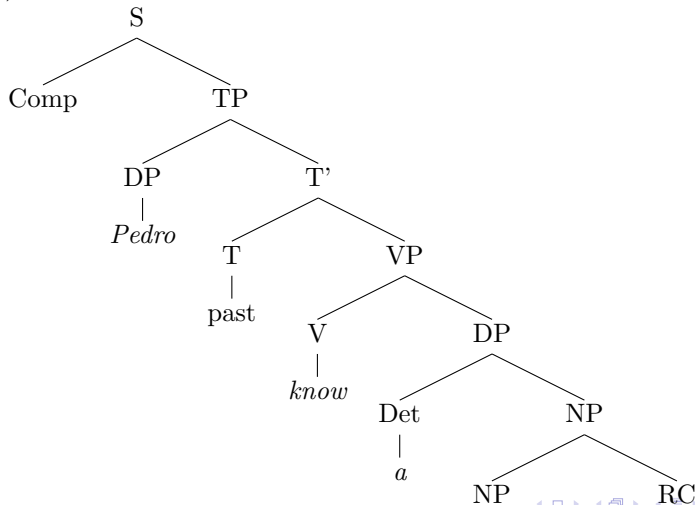

Relative Clauses

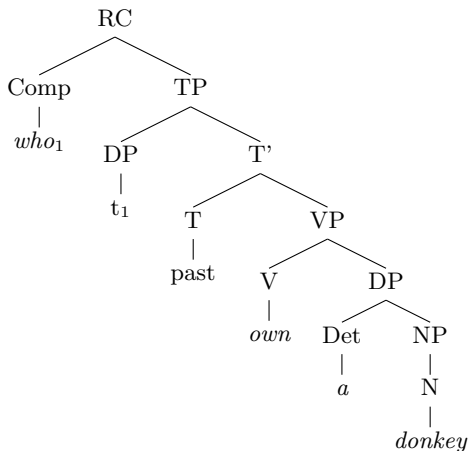

Relative Clauses

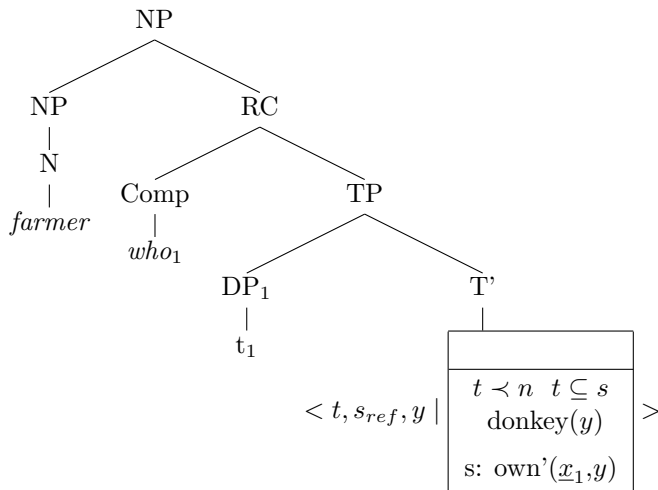

Relative Clauses

(214)

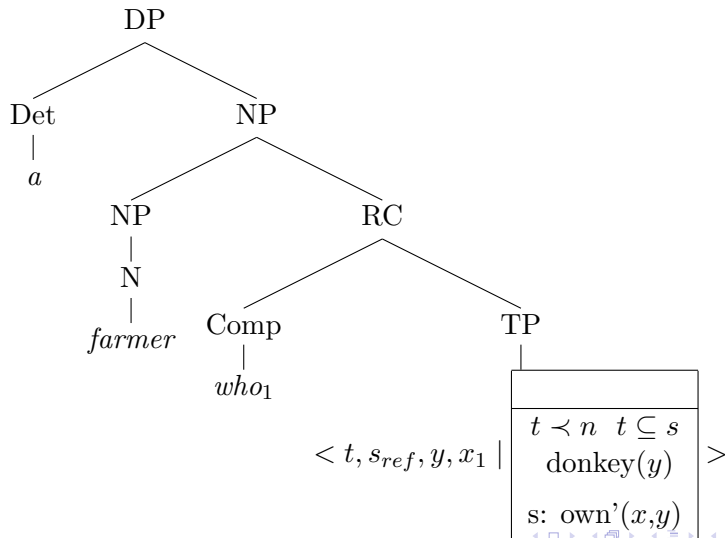

Relative Clauses

(215)

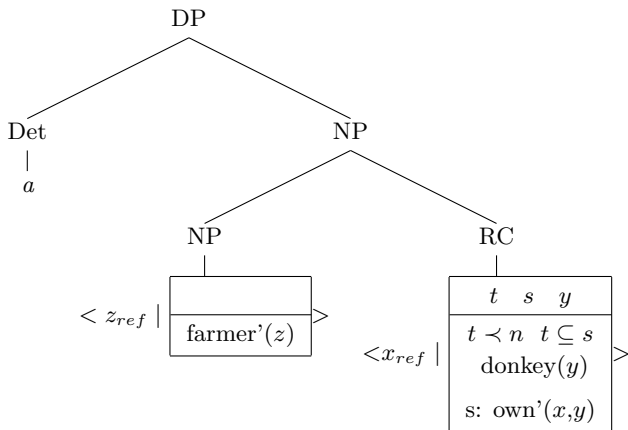

Relative Clauses

(216)

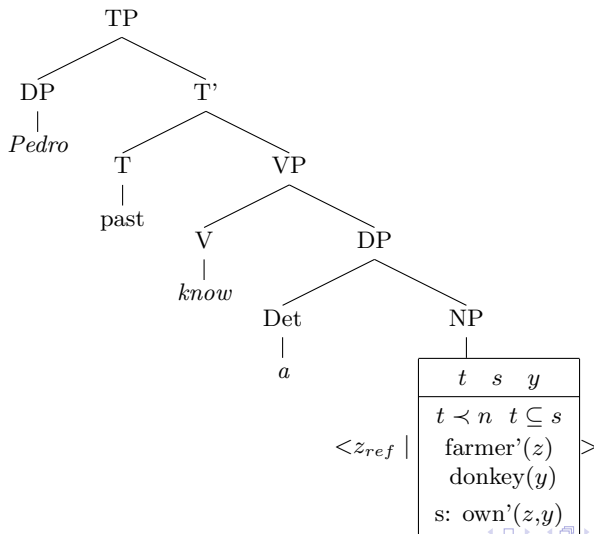

Relative Clauses

(217)

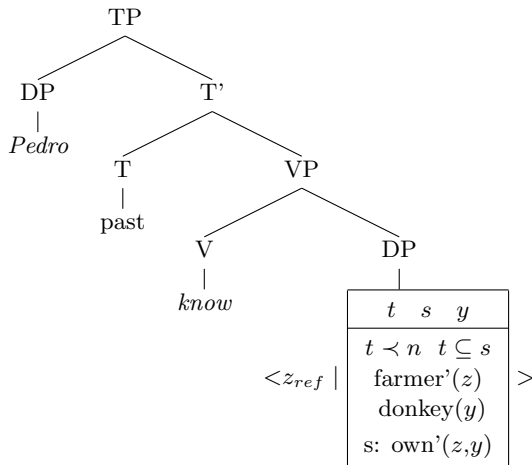

Relative Clauses

(218)

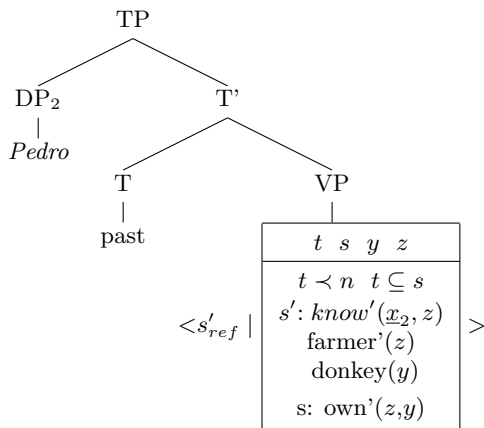

The remaining steps are left to you.

Negation

- There are important interactions between Negation and Aspect.

Interaction with imperfective aspect (for us: state descriptions) is the more straightforward case.

Consider the sentences in (219).

- (219)a. Johnny is happy.
b. Johnny lives in Paris.
c. Johnny isn't happy.
d. Johnny doesn't live in Paris.

- We adopt the following principle about the relation between state descriptions and the state descriptions obtained by negating those descriptions.

(220) Suppose that for no $t' \subseteq t$ there is a state s instantiating S such that $t' \subseteq s$. Then there is a state s' instantiating *not* – S such that $t \subseteq s'$.

Negation

What is the meaning of the negations of simple past tense state describing sentences?

- (221)a. Johnny wasn't happy.
b. Johnny didn't live in Paris.

Compare these with negated Simple Past Tense event sentences.

- (222)a. Johnny didn't cry.
b. Mary didn't meet a senator.
c. Mary didn't greet a senator.

Also consider the notorious example from Partee:

- (223) I didn't turn off the stove.

- We assume Neg has its own projection level, between PerfP and TP.

As an example, the syntactic structure for 'Fred hasn't paid the rent' is shown on the next slide.

Negation

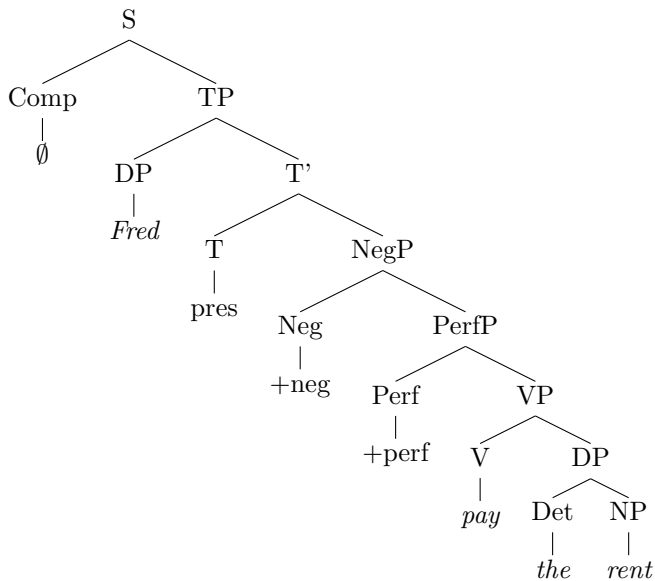

Negation

- A ‘puzzle’ about aspect and negation.

(224)

- a. When Alan opened his eyes he saw his wife who was standing by his bedside.
She smiled.
- b. When Alan opened his eyes he saw his wife who was standing by his bedside.
She was smiling.
- c. When Alan opened his eyes he saw his wife who was standing by his bedside.
She didn't smile.
- d. When Alan opened his eyes he saw his wife who was standing by his bedside.
She wasn't smiling.

Negation

- What we saw in the last set of examples is consistent with the difference between (225.a) and (225.b).

(225)

- a. Johnny isn't crying.
- b. Johnny doesn't cry.

(225.a) only has an episodic reading.

(225.b) only has a dispositional/generic reading.

Negation

- A lot of attention has been paid to the scope relations between negation and overt quantifiers.
- (226)a. Mary didn't know every philosopher in the room.
b. Mary didn't know any philosopher in the room.
c. Mary didn't know some philosopher in the room.
d. Mary didn't know a philosopher in the room.
e. Mary didn't give a passing grade to every student in the class.
f. Every philosopher in the room didn't know Mary.
g. Every philosopher isn't a charlatan.
h. Not every philosopher is a charlatan.

But the scope question amplifies when we also pay attention to time.

Negation

- DRS constructions for the sentences in (227).

(227)a. Johnny didn't cry.

b. Fred hasn't paid the rent.

LF for (227.a).

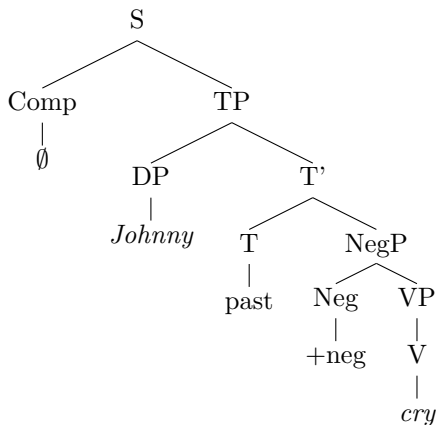

Negation

(228)

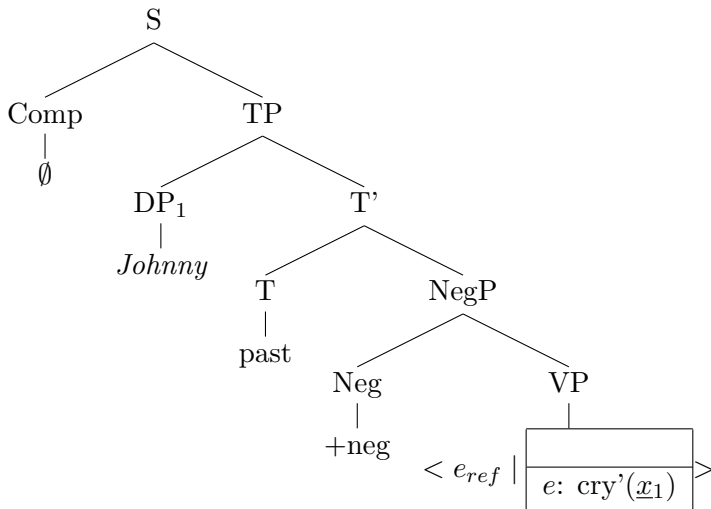

Negation

(229)

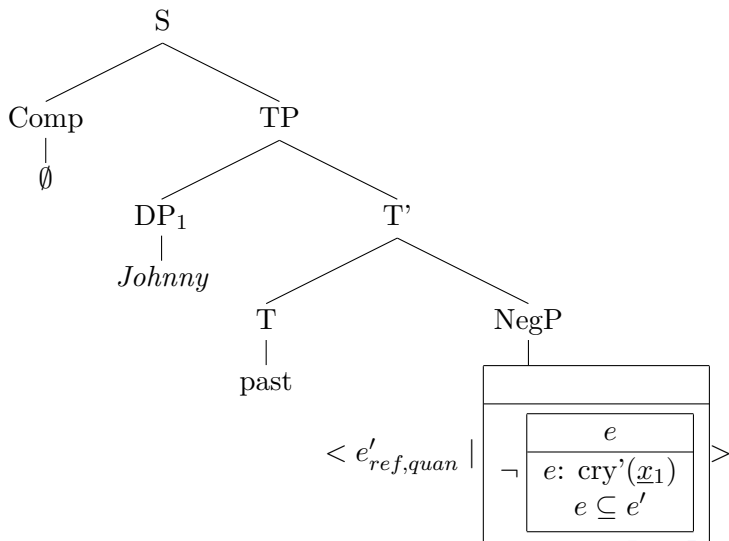

Negation

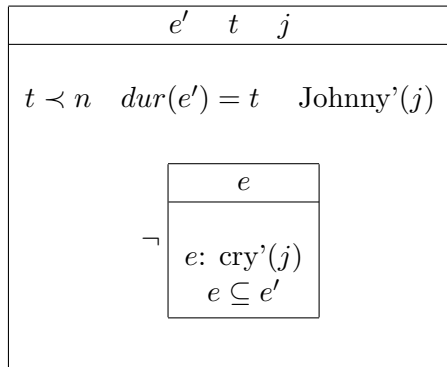

(230)

Negation

(231)

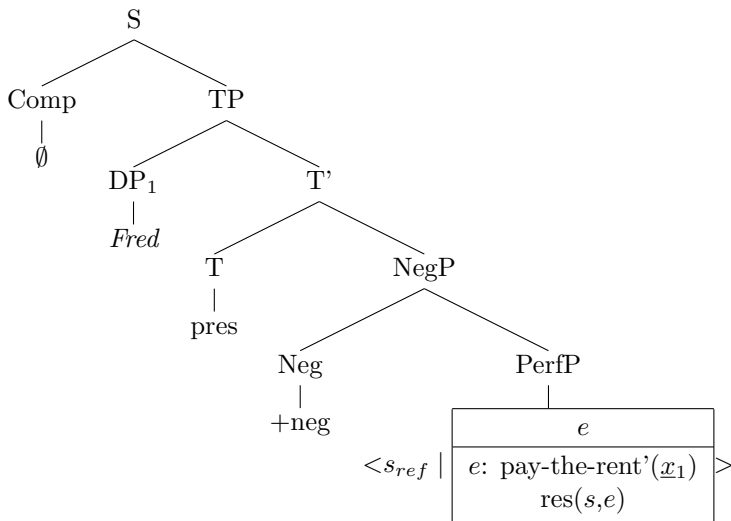

Negation

(232)

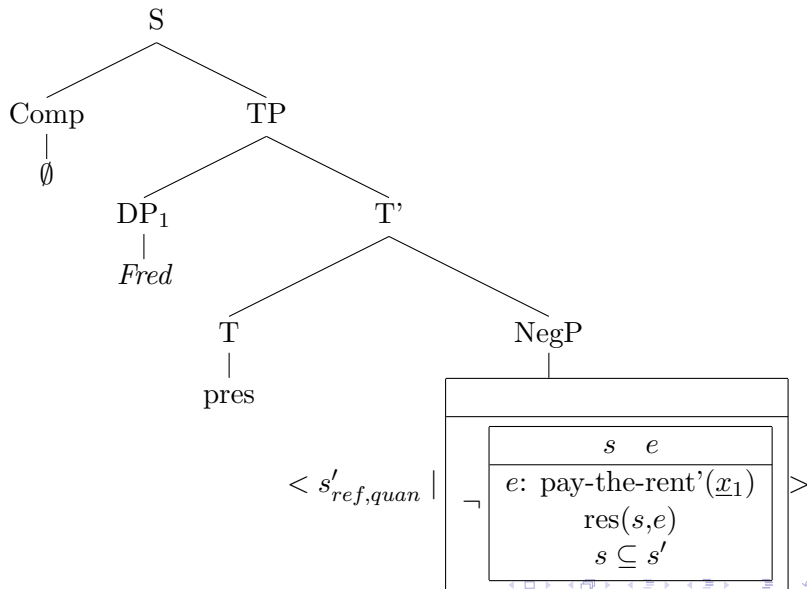

Negation

(233)

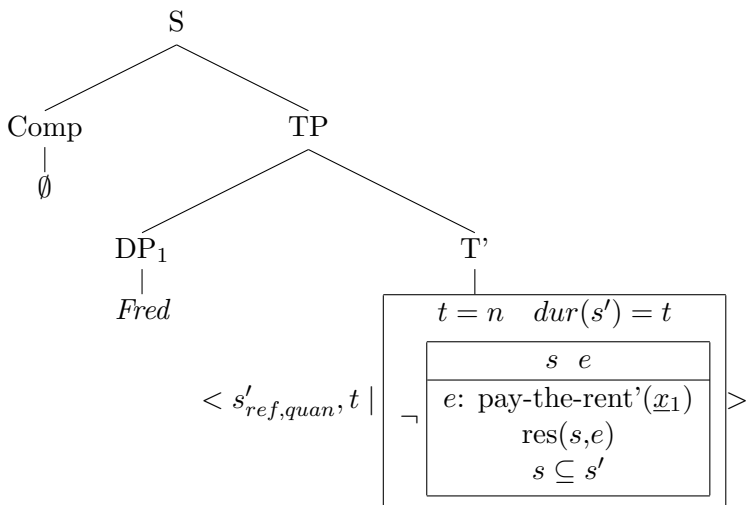

Negation

(234)

s'	t	f								
$t = n$	$dur(s') = t$	$Fred'(f)$								
<table border="1"><thead><tr><th>s</th><th>e</th></tr></thead><tbody><tr><td>\neg</td><td>$e: \text{pay-the-rent}'(f)$</td></tr><tr><td></td><td>$res(s,e)$</td></tr><tr><td></td><td>$s \subseteq s'$</td></tr></tbody></table>			s	e	\neg	$e: \text{pay-the-rent}'(f)$		$res(s,e)$		$s \subseteq s'$
s	e									
\neg	$e: \text{pay-the-rent}'(f)$									
	$res(s,e)$									
	$s \subseteq s'$									

Negation

(235) (lexical entry for the feature +neg)

+neg

Sel. Restr: eventuality description

Sem.Repr: $\langle ev_{ref}, \dots \mid K \rangle \rightsquigarrow$

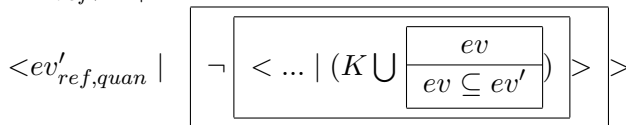

Input-output constraint:

if ev is an event, then ev' is an event;
if ev is a state then ev' is a state.

Presupposition

- A brief history of presupposition, from Frege to Van Der Sandt.
- Frege: We want terms in our formalism (in essence: the Predicate Calculus) of the form:

$$\iota x.\phi(x),$$

where $\phi(x)$ is a PC formula with (normally) one or more free occurrences of x .

- When there is a unique x such that $\phi(x)$, then $\iota x.\phi(x)$ denotes that x .
- When there is no unique x satisfying $\phi(x)$, then $\iota x.\phi(x)$.

In this case no PC sentence in which $\iota x.\phi(x)$ occurs as an argument has a truth value.

- Frege saw this as a serious problem, as sentences without truth value threaten to wreak havoc on the logic.

Presupposition

- Russell thought there was a simple and elegant solution to this problem:

Treat definite descriptions as quantifying DPs.

More specifically, the determiner *the* is a quantifying determiner (with the semantics shown below).

Consider for instance the sentence (263).

(236) The smallest prime is even.

In PC notation Russell's analysis of this sentence is as follows:

$$(\exists x)(\textit{prime}'(x) \ \& \ \neg((\exists z)(\textit{prime}'(z) \ \& \ \textit{smaller-} \\ \textit{than}'(z, x) \ \& \ (\forall y)((\textit{prime}'(y) \ \& \ \neg(\exists z)(\textit{prime}'(z) \ \& \ \textit{smaller-} \\ \textit{than}'(z, y)))) \rightarrow y = x) \ \& \ \textit{even}'(x))$$

Presupposition

- According to Russell's Theory of Descriptions (RTD) simple sentences with non-denoting descriptions always come out false, irrespective of what they (try to) predicate of the non-denoting description.

For instance, both sentences in (237) come out as false claims.

(237)

- a. The Emperor of China is Mongolian.
- b. The Emperor of China is not Mongolian.

More precisely, utterances of these sentences that would be made now are false because there is no Emperor of China those days.

Russell's analysis of (237.a):

(238) $(\exists x)(emperor'(x, c) \ \& \ (\forall y)((emperor'(y, c) \rightarrow y = x) \ \& \ Mongolian'(x)))$

Presupposition

- The first serious challenge to Russell's account of definite descriptions came with Strawson's 'On Referring' (1950)
- Strawson criticized Russell for failing to distinguish between failure to denote and mere gibberish.
- The sentence 'The King of France is bald' is just as meaningful now as it was 300 years ago.

The only difference is that an utterance of it 300 years ago would have expressed a proposition, which would have had a truth value.

When uttered today, the sentence does not express a proposition.

So the utterance is neither true nor false.

Presupposition

- The reason for this difference, as Strawson stated it not long afterwards, is that a definite description like *the king of France* comes with a presupposition:

The description must pick out a unique satisfier in the context in which it is used.

For a use of *the Emperor of China* 300 years ago this presupposition would have been satisfied.

When *the Emperor of China* is used today (in a simple present tense sentence), it is not.

Presupposition

- Failure of a presupposition associated with some part of a sentence S renders the use of the sentence inappropriate.

Usually this applies not only to S itself but also to its negation.

For instance, utterances today of both ‘Emperor of China’ sentences are bad, and for the same reason:

The two sentences come with the same presupposition.

When this presupposition fails, they are equally affected.

- The phenomenon that a presupposition equally affects a sentence and its negation can be used as a test for presupposition:
- This test is known as the *Negation Test*.

Presupposition

- In the late 60s linguists began to realize that there are many more presupposition ‘triggers’ than just definite descriptions.

(239)a. **Factive verbs.**

(i) emotive: *regret, be happy, be sorry, ..*

(ii) epistemic: *know, realize, discover,..*

Example: ‘John regrets/doesn’t regret that he went to the concert.’

Presupposes that John went to the concert.

Presupposition

- (240)a. **Aspectual verbs:** *stop, start, begin, continue, carry on, remain,..*

Example: John has/hasn't stopped smoking.'

Presupposes that John smoked at some time in the past.

- b. **Additive particles:** *too, also, as well, even,..*
'Nixon is/isn't guilty too.'

Default interpretation: Presupposes that someone other than Nixon is guilty.

Presupposition

(241)a. **again**

Example: ‘Mary closed/did not close the window again.’

Two possible interpretations:

(i) Presupposes that Mary closed the window before
(*repetitive* reading of *again*)

(ii) Presupposes that the window was previously closed
(*restitutive* reading of *again*)

b. **Clefts**

‘It was/wasn’t Fred who solved the problem.’

Presupposes that someone solved the problem.

Presupposition Projection

In some of the sentences below the presupposition that John has children projects and in others it doesn't.

- (242)a. If John has children, then his children are bald.
- b. If John is bald, then his children are bald.
- c. If John's children are bald, then John is bald.
- d. If John's children are bald, then he has children.
- e. If John has sons, then at least some of his children are bald
- f. If at least some of his children are bald, then John has sons.
- g. If John doesn't have children, then his children are bald. (???)
- h. If John didn't have children, then his children would have been bald. (???)
- i. John has children and, moreover, his children are bald.
- j. John is bald and, moreover, his children are bald.
- k. John's children are bald and, moreover, he is bald.
- l. John's children are bald and, moreover, he has children. (???)

Presupposition Projection

Similar observations for the presupposition That John went to the party, triggered by *regret*.

- (243)a. If John went to the party, then he regrets that he went to the party.
- b. If John is bald, then he regrets that he went to the party.
- c. If John regrets that he went to the party, then he went to the party.
- d. If Mary didn't want to talk to John at the party, then he regrets that he went to the party.
- e. If John didn't go to the party, then he regrets that he went to the party. (???)
- f. John went to the party and he regrets it.

DRS Construction for Discourses with Presuppositions

(244) It rained yesterday. It rained again today.

(245) $\langle e \mid \boxed{\begin{array}{c} \phantom{e: \text{rain}'} \\ \hline e: \text{rain}' \end{array}} \rangle.$

(246)

$e \quad t \quad d \quad d'$				
$t \prec n \quad e \subseteq t$				
$\text{day}(d)$	$\text{day}(d')$	$n \subseteq d'$	$d \supset \subset d'$	$e \subseteq d$
$e : \text{rain}'$				

DRS Construction for Discourses with Presuppositions

(247)

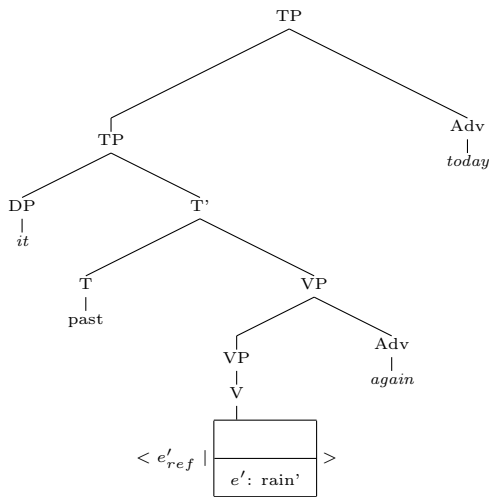

DRS Construction for Discourses with Presuppositions

(248)

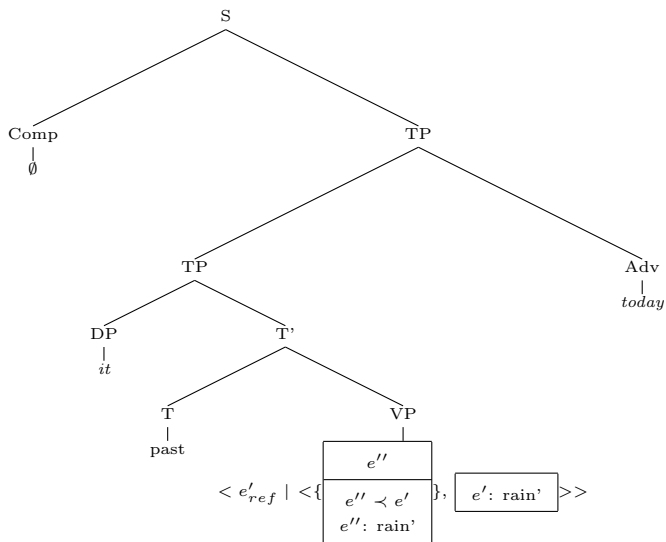

DRS Construction for Discourses with Presuppositions

(249)

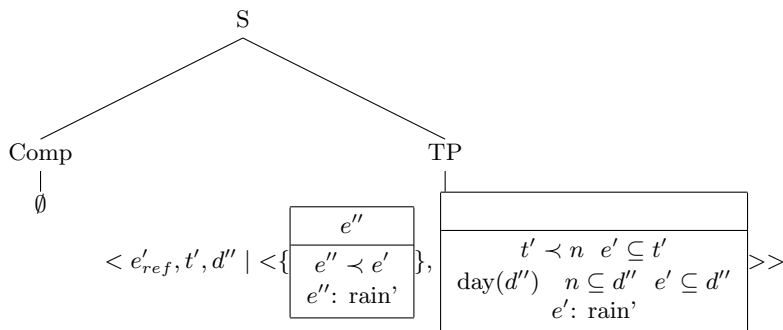

DRS Construction for Discourses with Presuppositions

(250) $\langle \{$

e''
$e'' \prec e'$
$e'': \text{rain}'$

$\},$

$e' \ t' \ d''$
$t' \prec n \ e' \subseteq t'$
$\text{day}(d'') \ n \subseteq d'' \ e' \subseteq d''$
$e': \text{rain}'$

\rangle

DRS Construction for Discourses with Presuppositions

(251)

e		t		d		d'		e'		t'		d''	
$t \prec n \quad e \subseteq t$													
$\text{day}(d)$		$\text{day}(d')$		$n \subseteq d'$		$d \supset \subset d'$		$e \subseteq d$		$e: \text{rain}'$			
$t' \prec n$		$e' \subseteq t'$		$\text{day}(d'')$		$n \subseteq d''$		$e' \subseteq d''$		$e': \text{rain}'$			

|=

e''
$e'' \prec e'$
$e'': \text{rain}'$

DRS Construction for Discourses with Presuppositions

- (252)a. It rained yesterday. (But) it didn't rain again today.
- b. It didn't rain yesterday. It didn't rain again today.

DRS Construction for Discourses with Presuppositions

(253)

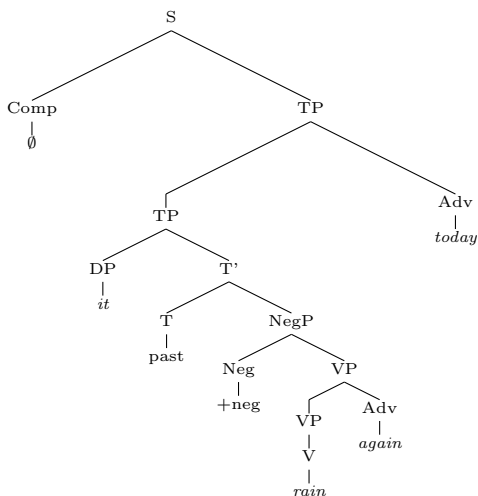

DRS Construction for Discourses with Presuppositions

(254)

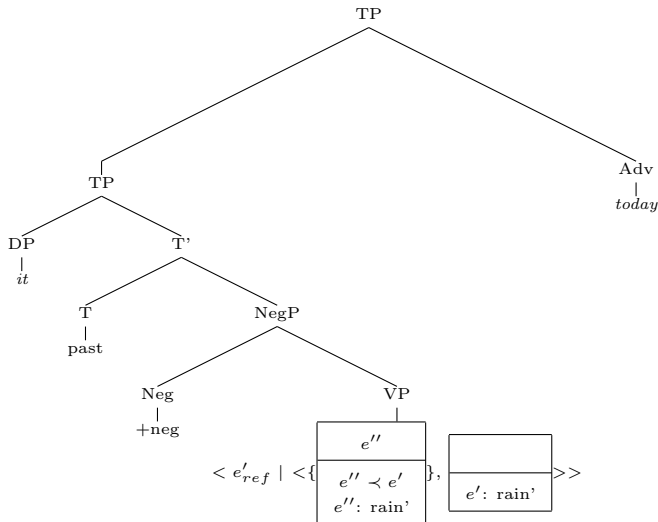

DRS Construction for Discourses with Presuppositions

(255)

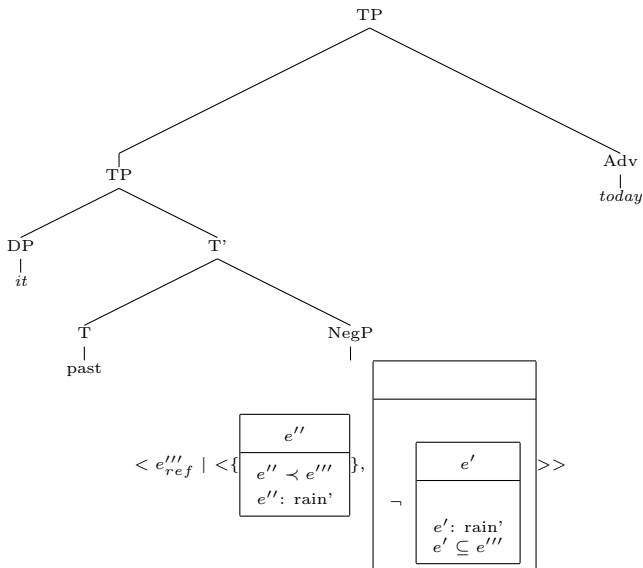

DRS Construction for Discourses with Presuppositions

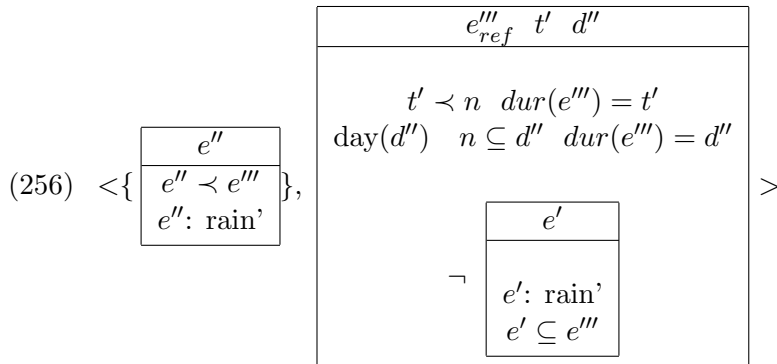

DRS Construction for Discourses with Presuppositions

$e \quad t \quad d \quad d' \quad d'' \quad e''' \quad t'$		
$t \prec n \quad e \subseteq t$ $\text{day}(d) \quad \text{day}(d') \quad n \subseteq d' \quad d \supset\subset d' \quad e \subseteq d$ $e : \text{rain}'$		
$t' \prec n \quad \text{dur}(e''') = t'$ $\text{day}(d'') \quad n \subseteq d'' \quad \text{dur}(e''') = d''$		
\neg <table border="1" style="margin-left: auto; margin-right: auto; border-collapse: collapse;"> <tr> <td style="padding: 5px; text-align: center;">e'</td> </tr> <tr> <td style="padding: 5px; text-align: center;"> $e' : \text{rain}'$ $e' \subseteq e'''$ </td> </tr> </table>	e'	$e' : \text{rain}'$ $e' \subseteq e'''$
e'		
$e' : \text{rain}'$ $e' \subseteq e'''$		

(257)

DRS Construction for Discourses with Presuppositions

It didn't rain yesterday. It didn't rain again today.

(258)

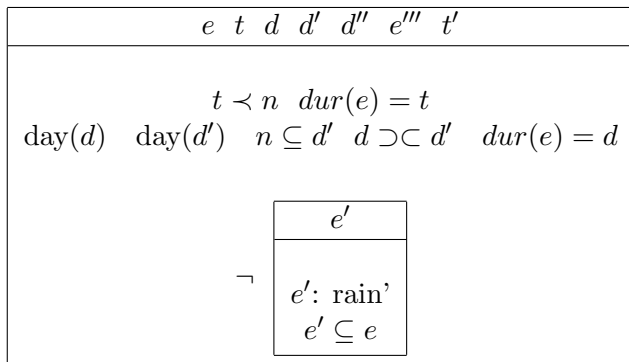

DRS Construction for Discourses with Presuppositions

(259)

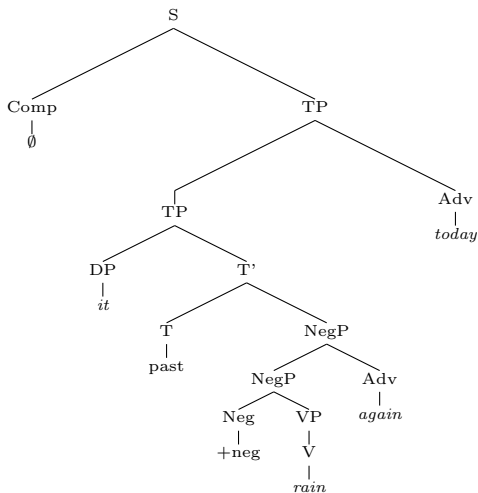

DRS Construction for Discourses with Presuppositions

(260)

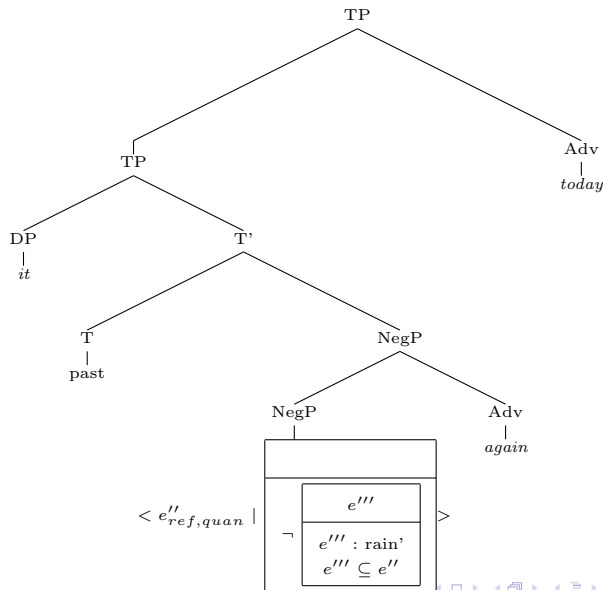

DRS Construction for Discourses with Presuppositions

(261)

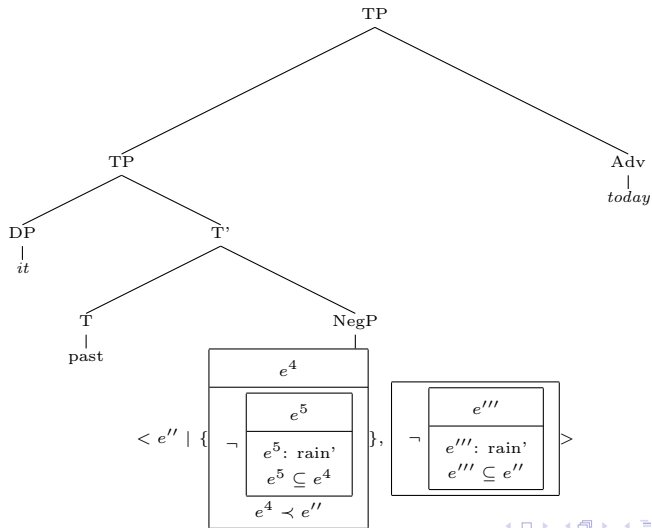

DRS Construction for Discourses with Presuppositions

(262)

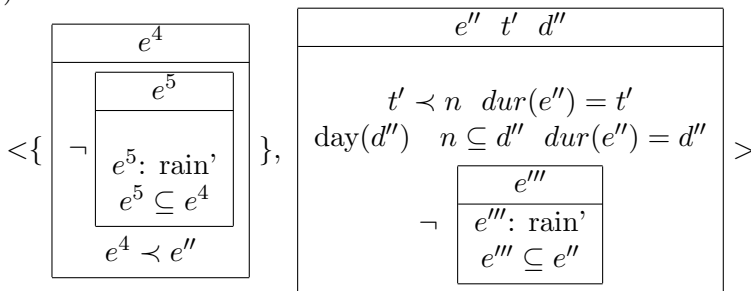

DRS Construction for Discourses with Presuppositions

(263)

$e \quad t \quad d \quad d' \quad d'' \quad e'' \quad t'$										
$t \prec n \quad dur(e) = t$										
$day(d)$	$day(d')$	$n \subseteq d'$	$d \supset \subset d'$	$dur(e) = d$						
<table border="1" style="margin: auto; border-collapse: collapse;"> <tr> <td style="text-align: center;">e'</td> </tr> <tr> <td style="text-align: center;">\neg</td> </tr> <tr> <td style="text-align: center;">$e': \text{rain}'$</td> </tr> <tr> <td style="text-align: center;">$e' \subseteq e$</td> </tr> </table>							e'	\neg	$e': \text{rain}'$	$e' \subseteq e$
e'										
\neg										
$e': \text{rain}'$										
$e' \subseteq e$										
$t' \prec n \quad dur(e'') = t'$										
$day(d'')$	$n \subseteq d''$	$dur(e'') = d''$								
<table border="1" style="margin: auto; border-collapse: collapse;"> <tr> <td style="text-align: center;">e'''</td> </tr> <tr> <td style="text-align: center;">\neg</td> </tr> <tr> <td style="text-align: center;">$e''': \text{rain}'$</td> </tr> <tr> <td style="text-align: center;">$e''' \subseteq e''$</td> </tr> </table>							e'''	\neg	$e''': \text{rain}'$	$e''' \subseteq e''$
e'''										
\neg										
$e''': \text{rain}'$										
$e''' \subseteq e''$										

Presuppositions of Definite Noun Phrases

- A new lexical entry schema for proper Names:

(264)

N (Proper Name)

x

Sel. Restr:

Sem.Repr:

$\langle x \mid \boxed{\text{Named}(x, N)} \rangle$

Presuppositions of Definite Noun Phrases

- Lexical entry schema for the Determiner of proper name DPs:

(265) (lexical entry)

$\emptyset_{pr.na.}$

Sel. Restr: —

Sem.Repr: $\left\langle x_{ref} \mid \begin{array}{|c|} \hline \\ \hline \text{Named}(x,N) \\ \hline \end{array} \right\rangle \rightsquigarrow$

$\left\langle x_{ref} \mid \left\langle \left\{ \begin{array}{|c|} \hline x? \\ \hline \text{Named}(x,N) \\ \hline \end{array} \right\}_{pr.na.} \right\rangle, \begin{array}{|c|} \hline \\ \hline \\ \hline \end{array} \right\rangle \right\rangle$

Presuppositions of Definite Noun Phrases

- Syntax and semantics of DPs that take the form of Proper Names:

(266)a.

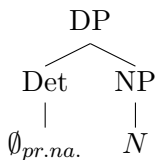

b.

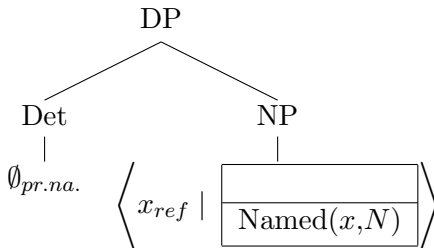

Presuppositions of Definite Noun Phrases

- Syntax and semantics of DPs that take the form of Proper Names:

(267)

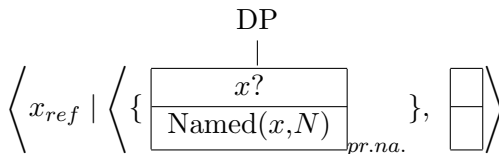

Presuppositions of Definite Noun Phrases

(268)a. Mary slept.

b.

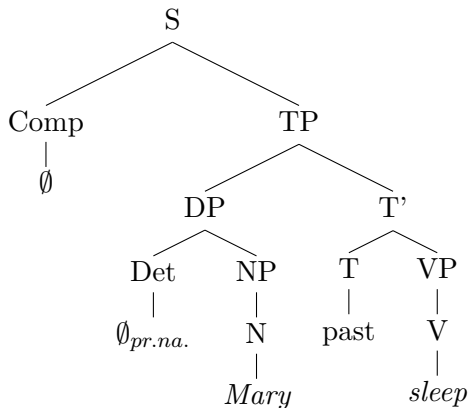

Presuppositions of Definite Noun Phrases

(269)

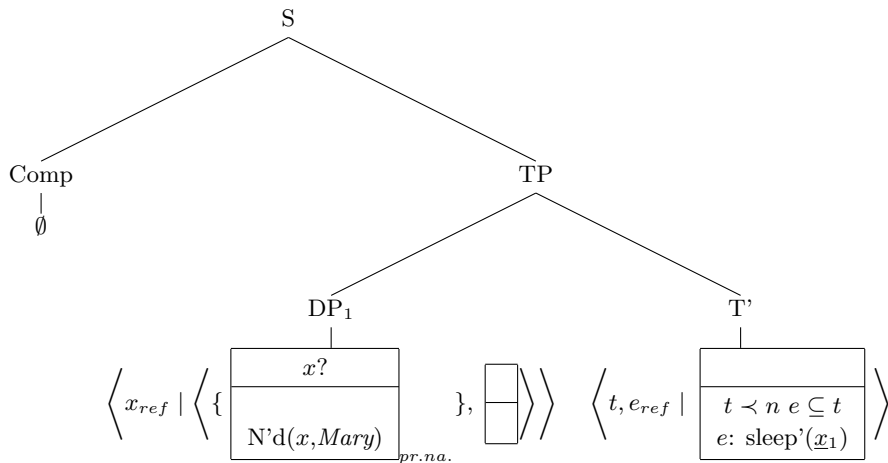

Presuppositions of Definite Noun Phrases

(272)

$t \quad e \quad x$
$t \prec n \quad e \subseteq t$ Named($x, Mary$) $e: \text{sleep}'(x)$

Presuppositions of Definite Noun Phrases

(273) If Mary slept, John didn't sleep.

(274)

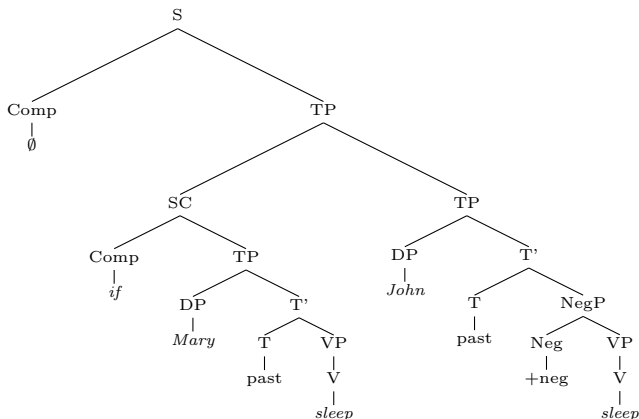

Presuppositions of Definite Noun Phrases

(275)

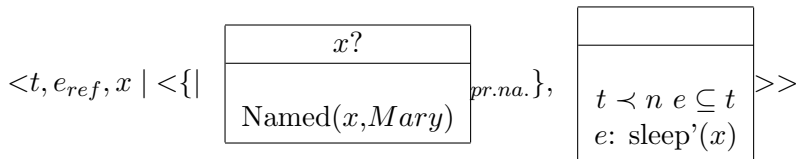

(276)

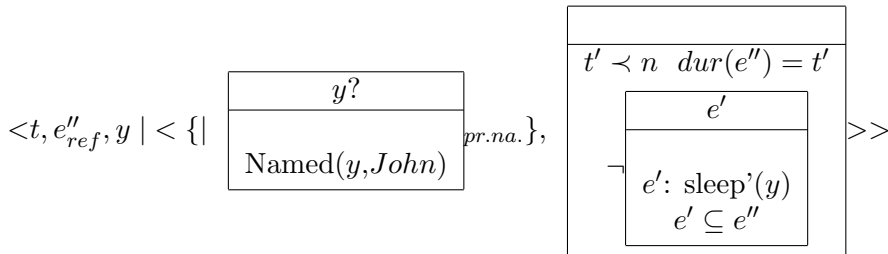

Presuppositions of Definite Noun Phrases

(277)

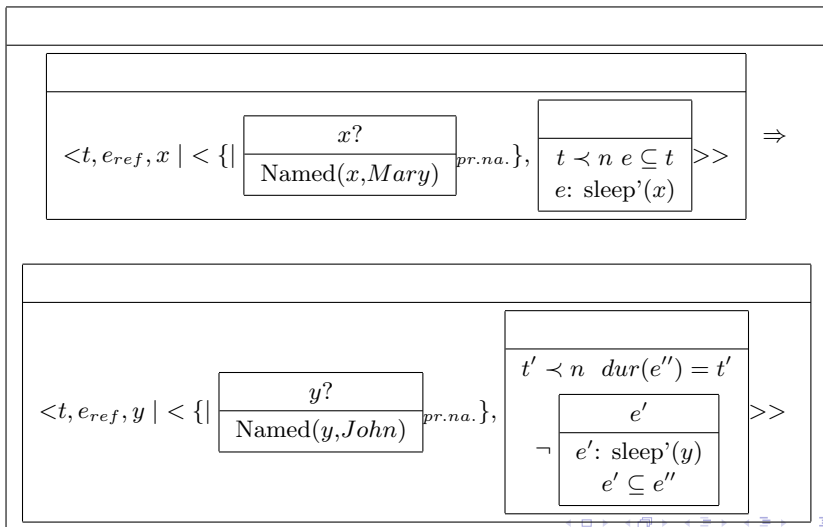

Presuppositions of Definite Noun Phrases

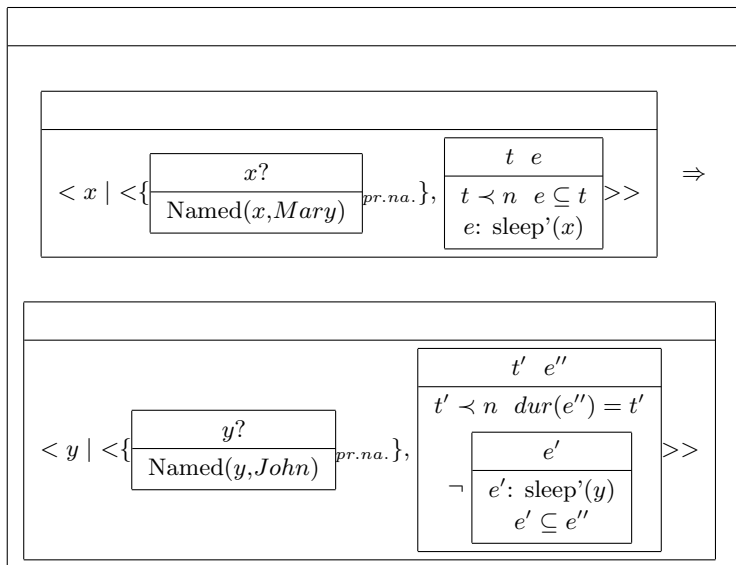

Presuppositions of Definite Noun Phrases

(278)

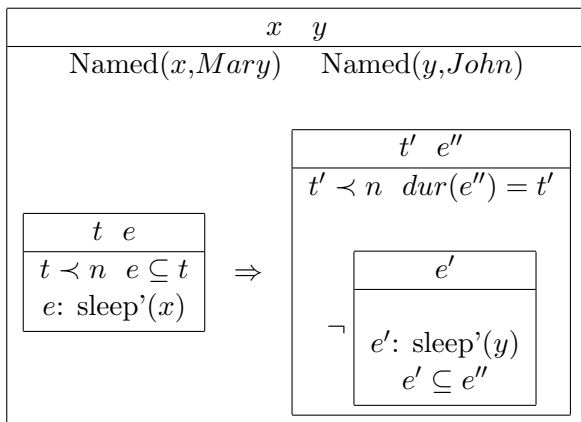

Presuppositions of Definite Noun Phrases

- Lexical entry for the 3rd person singular pronoun *she*.

(279) (lexical entry for the feature value ‘feminine’)

NP (feminine)

x

Sel. Restr:

Sem.Repr:

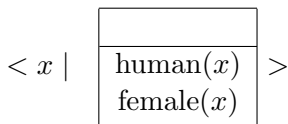

Presuppositions of Definite Noun Phrases

(280) (lexical entry for the feature value '3rd person')

3rd person

Sel. Restr: —

Sem.Repr: $\langle x_{ref} \mid \begin{array}{|c|} \hline \\ \hline \text{human}(x) \\ \text{female}(x) \\ \hline \end{array} \rangle \rightsquigarrow$

$\langle x_{ref} \mid \langle \{ \begin{array}{|c|} \hline x? \\ \hline \text{human}(x) \\ \text{female}(x) \\ \hline \end{array} \}_{3d.p.pr} \}, \begin{array}{|c|} \hline \\ \hline \end{array} \rangle \rangle$

Presuppositions of Definite Noun Phrases

(281)

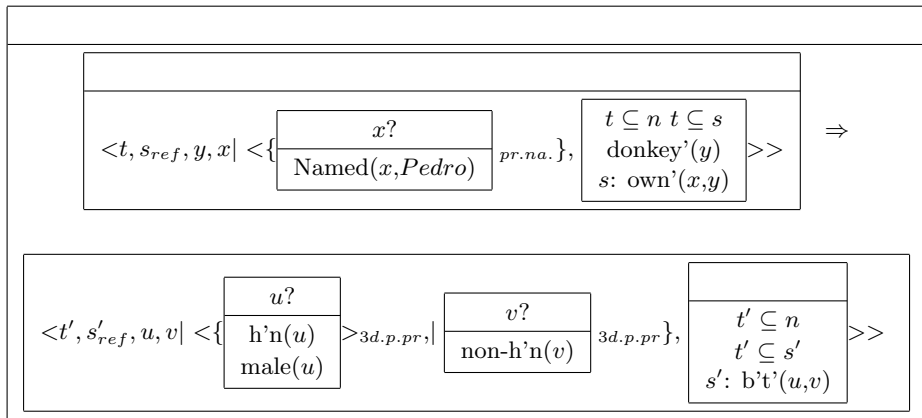

Presuppositions of Definite Noun Phrases

(282)

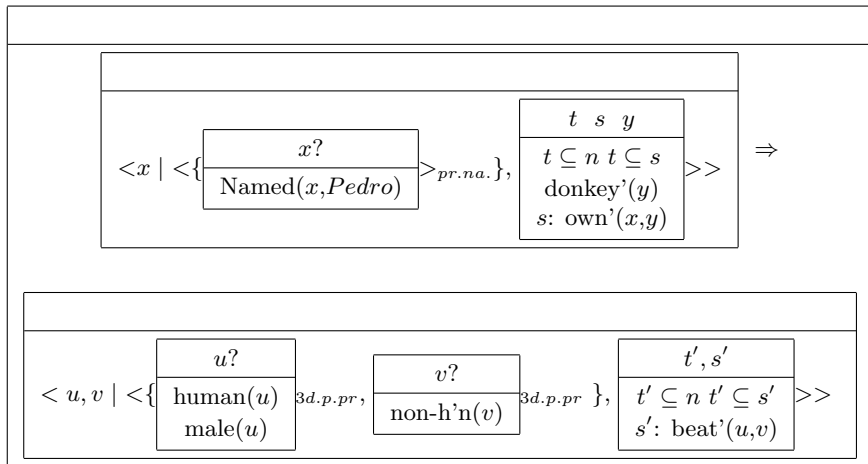

Presuppositions of Definite Noun Phrases

(283)

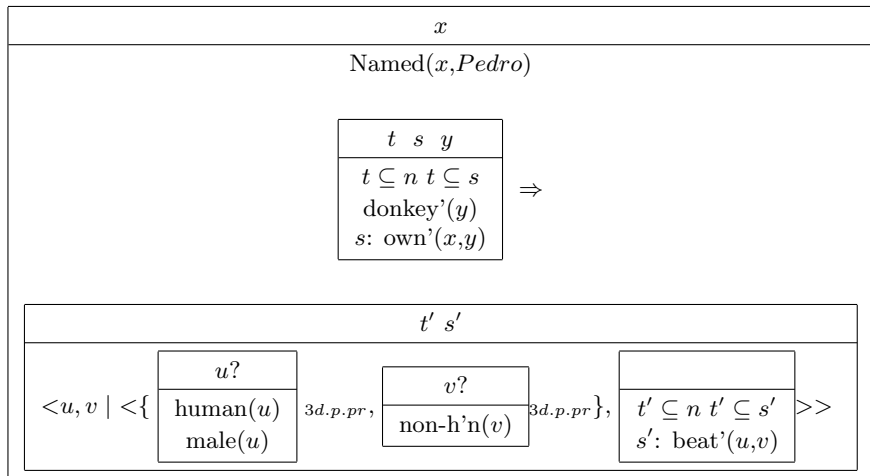

Presuppositions of Definite Noun Phrases

(284)

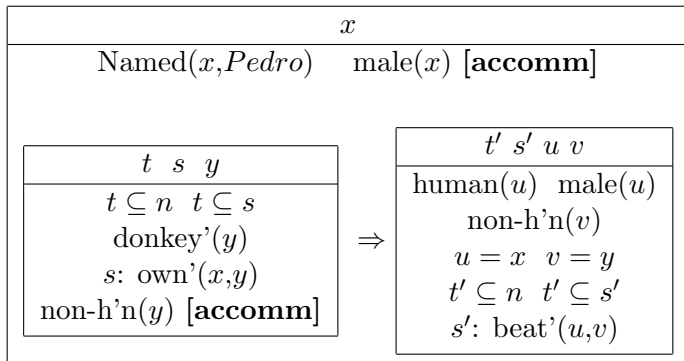

Constraints on the Resolution of 3rd Person Pronoun Presuppositions

- (285)a. He chased a woman who loathed a man.
b. A man chased a woman who loathed him.
- (286)a. John₁ admired *him₁/√himself₁.
b. He₁ admired *him₁/√himself₁.
c. Mary compared John₁ to *him₁/√himself₁.
d. John₁ was happy. He₁ admired *him₁/√himself₁.
e. John₁ found a snake near √him₁/√himself₁.
f. John₁ talked to Mary about ??him₁/√himself₁.

Constraints on the Resolution of 3rd Person Pronoun Presuppositions

- (287)a. If Pedro owns a donkey he beats it.
b. If a farmer owns a donkey he beats it.
c. Every farmer who owns a donkey beats it.
d. If he owns a donkey, Pedro beats it.
e. If Pedro owns it, he beats a donkey.
f. If he owns it, Pedro beats a donkey.
g. He beats it, if Pedro owns a donkey.
h. He beats a donkey, if Pedro owns it.
i. Pedro beats it, if he owns a donkey.
j. Pedro beats a donkey, if he owns it.

Constraints on the Resolution of 3rd Person Pronoun Presuppositions

A tangle of problems we briefly discussed earlier: Why are all these sentences good?

- (288)a. If a farmer owns it, he beats a donkey.
- b. If he owns a donkey, a farmer beats it.
- c. If he owns it, a farmer beats a donkey.
- d. He beats it, if a farmer owns a donkey.
- e. He beats a donkey, if a farmer owns it.
- f. A farmer beats it, if he owns a donkey.
- g. A farmer beats a donkey, if he owns it.
- h. Every farmer who owns it beats a donkey.
- i. Every farmer beats it, if he owns a donkey.
- j. Every farmer beats a donkey, if he owns it.

Definite Descriptions

General assumption: Definite Descriptions presuppose unique satisfaction of ‘their’ descriptive content.

But in general this descriptive content relies heavily on the context.

Our implementation: The unique satisfaction presupposition comes with a subsidiary anaphoric presupposition which demands a suitable resolution for a Domain Restriction Predicate C .

The Condition $C(x)$ – where x is the referential argument of the definite description – is conjoined with the definite description’s explicitly given descriptive content.

It is this conjunction that is required to have a unique satisfier.

Definite Descriptions

(289) (lexical entry for singular *the*)

the (Det) NP

Sel. Restr:

Sem.Repr:

$\langle x_{ref}, \beta_2, \dots, \beta_n \mid \langle \mathcal{PR}, K \rangle \rangle \rightsquigarrow$

$\langle x_{ref}, \beta_2, \dots, \beta_n \mid \langle \mathcal{PR} \cup \{K_{pr.dd.}\}, \boxed{} \rangle \rangle$

$K_{pr.dd}$ is given on the next slide. K' is the DRS $K \oplus \boxed{} \frac{C(x)}{}$.

Definite Descriptions

$K_{pr.dd}$:

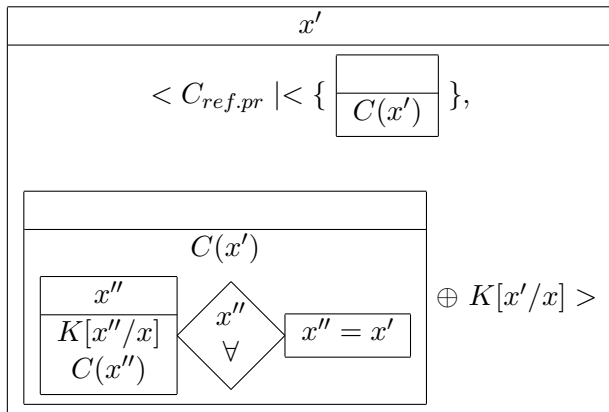

Presuppositions in the Temporal Location of Eventuality Descriptions

(290)(Reichenbach)

But Philip ceased to think of her a moment after he **had** settled down in his carriage. He thought only of the future. He **had** written to Mrs. Otter, the massière to whom Hayward **had** given him an introduction, and had in his pocket an invitation to tea on the following day.

(From: W. Somerset Maugham, *Of Human Bondage*)

Recall the pair of earlier examples that served to illustrate what is the core of Reichenbach's observation.

- a. John proved the theorem in twenty lines. Mary proved it in ten lines.
- b. John proved the theorem in twenty lines. Mary had proved it in ten lines.

Presuppositions in the Temporal Location of Eventuality Descriptions

- Lesson from Reichenbach:

State descriptions are located at a TPpt (Temporal Perspective point).

The tenses come with a presupposition to the effect that when the input description is the description of a state, then a TPpt needs to be found.

This requirement is formulated as an anaphoric presupposition that asks for the identification of a time to play the part of TPpt in the location of the described state.

When the input description is an event description, the location mechanism(s) is/are different. The following revised entry for the past tense leaves open what these mechanisms are.

Revised Lexical Entry for the Tense Feature ‘past’

past (tense feature)

Sel. Restr: eventuality description

Sem.Repr: $\langle ev_{ref}, \dots \mid K \rangle \rightsquigarrow$

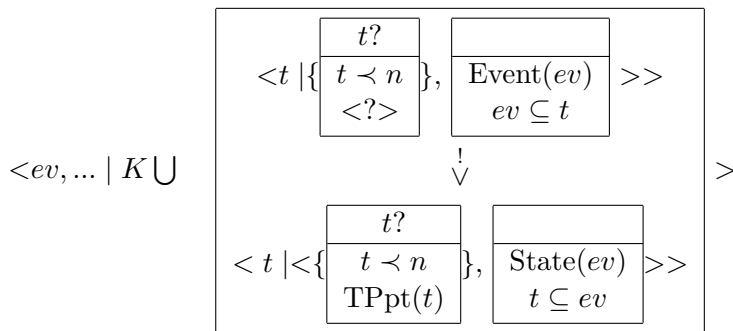

Presuppositions in the Temporal Location of of Eventuality Descriptions

John proved the theorem in twenty lines.

DRS:

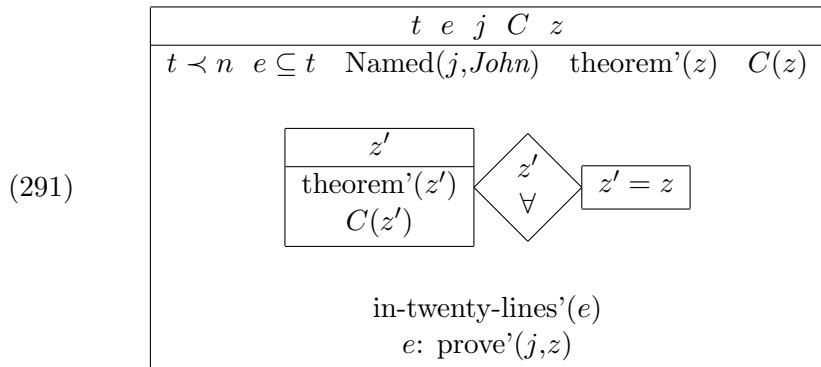

Presuppositions in the Temporal Location of of Eventuality Descriptions

Preliminary Representation of: ‘Mary had proved it in ten lines’:

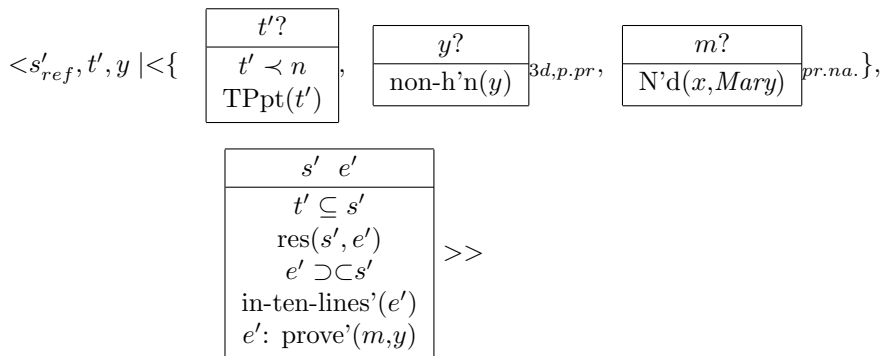

Presuppositions in the Temporal Location of Eventuality Descriptions

After resolution of the presuppositions of the last representation, using the DRS for the first sentence as discourse context:

(292)

t' s' e' m y
$\text{Named}(m, \text{Mary}) \quad y = z \quad t' = \text{dur}(e)$
$t' \subseteq s' \quad \text{res}(s', e')$
$e' \supset \subset s'$
$\text{in-ten-lines}'(e')$
$e': \text{prove}'(m, y)$
$e' \supset \subset s'$

Presuppositions in the Temporal Location of Eventuality Descriptions

Recall the following example pair:

When Alan opened his eyes he saw his wife who was standing by his

(i) She smiled.

(ii) She was smiling.

The second example, with ‘She was smiling’ as second sentence, can be treated along the same lines as the last one.

In this case it is the state description ‘be smiling’ that is located by the past tense.

Again a TPpt has to be found and again the only possible choice is an event form the discourse context.

Presuppositions in the Temporal Location of Eventuality Descriptions

There are two possible choices:

either the duration of the event of Alan his eyes or that of the event of his seeing his wife.

But the choice doesn't really matter much in this case.

The result: the state of Alan's wife smiling is located around the event whose duration is chosen to play the part of TPpt.

- A detailed account of the location of the event described by (i) 'She smiled' is different and more complex, involving rhetorical structure and causal reasoning.

CURTAIN

- Beaver, D., Geurts, B. & Maier, E. (2015), ‘Discourse representation theory’, *Stanford Encyclopedia of Philosophy* .
- Cooper, R. (1979), The interpretation of pronouns, *in* ‘Syntax & Semantics, vol 10’, Academic Press, pp. 61–92.
- Geach, P. (1962), *Reference and Generality : An Examination of Some Medieval and Modern Theories*, Cornell University Press, Ithaca.
- Kamp, H. (1981*a*), ‘Événements, représentations discursives et référence temporelle’, *Langages* **64**, 39–64. For the original English ms. from which the paper in *Langages* is the French translation, see *Semantics and Pragmatics*, Vol 10 (2017).
- Kamp, H. (1981*b*), A theory of truth and semantic representation, *in* J. Groenendijk et al., eds, ‘Formal Methods in the Study of Language’, Mathematisch Centrum, Amsterdam. Reprinted in: K. von Heusinger and A. Ter Meulen, ‘Meaning and the Dynamics of Interpretation. Selected Papers of Hans Kamp’. Brill, 2013.
- Kamp, H. (2019), Tense and aspect in discourse representation theory, *in* R. Truswell, ed., ‘The Oxford Handbook of Event Structure’, Oxford University Press.

- Kamp, H. & Reyle, U. (1993), *From Discourse to Logic*, Kluwer.
- Kamp, H., van Genabith, J. & Reyle, U. (2011), Discourse representation theory: An updated survey, in D. Gabbay, ed., 'Handbook of Philosophical Logic, Vol. XV', Elsevier, pp. 125 – 394.
- Lascarides, A. & Asher, N. (1993), 'Temporal interpretation, discourse relations, and common sense entailment', *Linguistics and Philosophy* **16**, 437–49.
- Partee, B. (1973), 'Some structural analogies between tenses and pronouns in english', *The Journal of Philosophy* **70**, 601–609.
- Thomason, R. (1974), *Formal Philosophy. Selected Papers of Richard Montague*, Yale University Press, New Haven and London.
- Webber, B. (1988), 'Tense as discourse anaphor', *Computational Linguistics* **14**(2), 61–73.